



STANDARDS ACTION

PUBLISHED WEEKLY BY THE AMERICAN NATIONAL STANDARDS INSTITUTE 25 WEST 43RD STREET NY, NY 10036

VOL. 53 | NO. 4

January 28, 2022

CONTENTS

American National Standards

Project Initiation Notification System (PINS)	2
Call for Comment on Standards Proposals	12
Final Actions - (Approved ANS)	34
Call for Members (ANS Consensus Bodies).....	39
Call for Comment of ANS Limited Substantive Changes.....	43
American National Standards (ANS) Announcements	44
Accreditation Announcements (Standards Developers)	45
Meeting Notices (Standards Developers)	46
American National Standards (ANS) Process	48
ANS Under Continuous Maintenance.....	49
ANSI-Accredited Standards Developer Contact Information.....	50

International Standards

ISO and IEC Draft Standards	52
ISO and IEC Newly Published Standards	58
International Organization for Standardization (ISO)	60
Meeting Notices (International).....	61

Registration of Organization Names in the United States	62
--	-----------

Proposed Foreign Government Regulations	63
--	-----------

Project Initiation Notification System (PINS)

ANSI Procedures require notification of ANSI by ANSI-accredited standards developers (ASD) of the initiation and scope of activities expected to result in new or revised American National Standards (ANS). Early notification of activity intended to reaffirm or withdraw an ANS and in some instances a PINS related to a national adoption is optional. The mechanism by which such notification is given is referred to as the PINS process. For additional information, see clause 2.4 of the ANSI Essential Requirements: Due Process Requirements for American National Standards.

Following is a list of proposed actions and new ANS that have been received recently from ASDs. Please also review the section in Standards Action entitled "American National Standards Maintained Under Continuous Maintenance" for additional or comparable information with regard to standards maintained under the continuous maintenance option. Use the following Public Document Library url to access PDF & EXCEL reports of approved & proposed ANS: [List of Approved and Proposed ANS](#)

Directly and materially affected interests wishing to receive more information or to submit comments are requested to contact the standards developer directly within 30 days of the publication of this announcement.

AMCA (Air Movement and Control Association)

30 West University Drive | Arlington Heights, IL 60004-1893 www.amca.org
Contact: Shruti Kohli-Bhargava; shrutik@amca.org

New Standard

BSR/AMCA 280-202x, Method of Test for Wind Loading of Fans (new standard)

Stakeholders: Fan manufacturers, building design engineers and architects, end-users, fan testing labs, and associations within the HVAC industry (trade associations and professional societies).

Project Need: To establish uniform methods for laboratory testing of wind resistance and large missile debris impact resistance of fans.

Scope: Tests conducted in accordance with this standard are intended to demonstrate a fan's capability to withstand wind pressure, lateral force, large missile impact(s), or any combination thereof. The test methodology, pass/fail criteria, and functional criteria will be defined. The wind pressure test methodology in this standard is intended to demonstrate a fan's ability to sufficiently retain its structural integrity as well as help maintain integrity of the building envelope. The lateral force test methodology in this standard is intended to demonstrate a fan's ability to sufficiently transfer the loads of a wind force to its attachment points and to the building structure. The large missile debris impact test methodology in this standard is intended to demonstrate a fan's ability to maintain structural integrity of its housing and of the components attached to it.

ASME (American Society of Mechanical Engineers)

Two Park Avenue, 6th Floor | New York, NY 10016-5990 www.asme.org

Contact: Maria Acevedo; ansibox@asme.org

New Standard

BSR/ASME PTC 19.25-202x, Non-Nulling Velocity Measurements of Air or Flue Gas Flows (new standard)

Stakeholders: Regulatory agencies, utility power plants, manufacturing facilities, refineries, testing contractors, test equipment manufacturers, wind tunnel calibration facilities.

Project Need: Industrial facilities, manufacturing plants, and electric power plants that burn fossil fuels exhaust the combustion products to atmosphere through their smokestacks. Stack pollutant emissions are quantified using manual testing methods developed in the 1960s, which are prone to error if complex flow patterns exist, which is common. The non-nulling test methodology will allow users to obtain the improved accuracy of the 3D flow test without any additional time. In addition to power plant RATA testing, this could be used to significantly reduce test times for fan performance. The new test method will also be applicable to flow measurements in other industries such as HVAC, refineries, heat exchangers, and more.

Scope: This document will provide guidance in test methodologies for measuring velocities and flows using a detailed probe calibration process and allows the user to calculate 3D velocities using non-nulling probes with 4 or more holes. These methodologies eliminate the additional time and uncertainty introduced by needing to measure yaw angle.

CSA (CSA America Standards Inc.)

8501 East Pleasant Valley Road | Cleveland, OH 44131-5575 www.csagroup.org

Contact: Debbie Chesnik; ansi.contact@csagroup.org

New Standard

BSR/CSA C800-202x, Testing Protocol for Energy Storage System Reliability and Quality Assurance Program (new standard)

Stakeholders: Financial institutions and insurers, first responders, manufacturers, regulatory and code officials, certification bodies, developers, independent engineers

Project Need: Currently available standards cover general safety requirements and performance of an energy storage system (ESS). However, considering the rapid penetration of energy storage system deployment into residential, commercial, and utility applications, there has not been a proper method to evaluate the behavior and reliability of the ESS during natural or accidental incidences and the related impact on the reliability and durability of the system and its components. Additionally, there is no available document to properly assess the bankability and insurability of energy storage which the proposed reliability and quality assurance program in this Standard is intended to cover.

Scope: This Standard provides an Electrical Energy Storage System (EESS) testing protocol for quality assurance and reliability programs. It is intended to be used by code officials, financial institutions and insurers, first responders, developers, independent engineers, manufacturers, and other relevant stakeholders in Energy Storage System industry. It provides best practices for an EESS testing protocol of a representative energy storage system for quality and reliability assurance programs. This Standard is intended to be a stand-alone document that does not interact with other safety or performance standards as it is intended to focus on reliability and quality assurance for long-term durability. Market practices as they currently exist might require independent quality assurance and reliability testing and due diligence for energy storage systems. The individual test legs in the protocol of this Standard have been designed to reproduce incidences and failures of a representative energy storage system that have been seen in the field or potentially could be seen in the field. Data generated from testing will reflect the behavior, reliability, and durability of the system and its components during natural or accidental occurrences of conflagration, inundation, convulsion, or other related incidences, as well as reflect the harsh environmental conditions during operation. This data is intended to be used as part of an assessment for bankability and insurability of energy storage systems.

HPS (ASC N13) (Health Physics Society)

1313 Dolley Madison Blvd, Suite 402 | McLean, VA 22101 www.hps.org

Contact: Amy Wride-Graney; awride-graney@burkinc.com

Revision

BSR N13.41-202x, Criteria for Performing Multiple Dosimetry (revision of ANSI N13.41-2011 (R2018))

Stakeholders: Government, medical, industrial.

Project Need: Need: This project impacts how different stakeholders may calculate effective doses. This standard requires certain weighting factors to be used, whereas technical justification for other values should be permitted while allowing a program to maintain compliance with the standard. Furthermore, organ distribution between body compartments should be reevaluated.

Scope: This standard provides criteria for when and how to use multiple dosimeters under conditions incident to routine activities that may involve non-uniform exposures to ionizing radiation. It also contains the recommended methodology for determining the effective dose from external sources when the use of multiple dosimeters has been deemed necessary by radiation protection professionals. This revision will address inconsistencies and variations observed between the ICRPs while granting flexibility to those who wish to adhere to a standard.

NEMA (ASC C8) (National Electrical Manufacturers Association)

1300 North 17th Street, Suite 900 | Arlington, VA 22209 www.nema.org

Contact: Khaled Masri; Khaled.Masri@nema.org

Revision

BSR ICEA P-45-482-202x, Short Circuit Performance of Metallic Shields and Sheaths on Insulated Cable (revision of ANSI/ICEA P-45-482-2017)

Stakeholders: Wire manufacturers, builders, and installers.

Project Need: Periodic Review of Standard.

Scope: Equations and parameters have been established for short-circuit calculations for sheaths or shields made of aluminum, bronze, copper, lead, steel, zinc, and cupronickel alloys.

NEMA (ASC C8) (National Electrical Manufacturers Association)

1300 North 17th Street, Suite 900 | Arlington, VA 22209 www.nema.org

Contact: Khaled Masri; Khaled.Masri@nema.org

Revision

BSR ICEA S-122-744-202x, Standard for Optical Fiber Outside Plant Microduct Cables (revision of ANSI ICEA S-122-744-2016)

Stakeholders: Manufacturers, builders, and users of optical fiber cable.

Project Need: This Standard covers performance requirements for microduct optical fiber outside plant cables intended for installation in microducts.

Scope: This Standard covers performance requirements for microduct optical fiber outside plant cables intended for installation in microducts, typically by blowing in using commercially available equipment intended for this application. Products covered by this Standard are intended only for operation under conditions normally found in outside plant communication systems.

NEMA (ASC C8) (National Electrical Manufacturers Association)

1300 North 17th Street, Suite 900 | Arlington, VA 22209 www.nema.org

Contact: Khaled Masri; Khaled.Masri@nema.org

Revision

BSR ICEA S-86-634-202x, Standard for Buried Telecommunications Wire Filled, Polyolefin Insulated, Copper Conductor - Technical Requirements (revision of ANSI/ICEA S-86-634-2011 (R2017))

Stakeholders: Installers of telecom equipment, telecom service providers.

Project Need: The standard needs revision.

Scope: This Standard covers mechanical and electrical requirements for filled, polyolefin insulated, copper conductor, buried telecommunications wire. It provides alternative choices for type of insulation, type of filling compound, sheath design (shielding materials, single or double jackets, and jacket type and thickness) and armoring. Buried wire is used to extend buried telephone plant from the distribution cable to the subscriber.

NEMA (ASC C8) (National Electrical Manufacturers Association)

1300 North 17th Street, Suite 900 | Arlington, VA 22209 www.nema.org

Contact: Khaled Masri; Khaled.Masri@nema.org

Revision

BSR ICEA T-32-645-202x, Test Method for Establishing Volume Resistivity Compatibility of Water Blocking Components with Extruded Semiconducting Shield Materials (revision of ANSI/ICEA T-32-645-2017)

Stakeholders: Users, producers, and other parties interested in insulated cable.

Project Need: This test method provides procedures for establishing volume resistivity compatibility of water-blocking components with extruded semiconducting shields utilized in MV, HV, or EHV power cables.

Scope: This test method provides procedures for establishing volume resistivity compatibility of water blocking components with extruded semiconducting shields utilized in MV, HV, or EHV power cables. The compatibility test is designed to verify that the electrical properties of a semiconducting material used as a conductor or insulation shield are not adversely affected when exposed to a water-blocking component.

NEMA (ASC C8) (National Electrical Manufacturers Association)

1300 North 17th Street, Suite 900 | Arlington, VA 22209 www.nema.org

Contact: Khaled Masri; Khaled.Masri@nema.org

Revision

BSR/ICEA S-75-381/NEMA WC 58-202x, Portable and Power Feeder Cables for Use in Mines and Similar Applications (revision of ANSI/ICEA S-75-381-2017/NEMA WC 58-2017)

Stakeholders: Users and producers of insulated cables.

Project Need: Standard revision cycle.

Scope: These standards apply to materials, construction, and testing of insulated cables used for the utilization of electrical energy in surface and underground mines and similar applications. Included are portable cables for use in mining machines, dredges, shovels, and similar equipment, and mine power cables for use as connections between units of mine distribution systems, and remote control and drill cords for mining and similar applications

NEMA (ASC C8) (National Electrical Manufacturers Association)

1300 North 17th Street, Suite 900 | Arlington, VA 22209 www.nema.org

Contact: Khaled Masri; Khaled.Masri@nema.org

Revision

BSR/NEMA ICEA S-93-639/WC 74-202x, 5-46 kV Shielded Power Cable for Use in the Transmission and Distribution of Electric Energy (revision of ANSI/NEMA ICEA S-93-639/WC 74-2017)

Stakeholders: Utility and manufacturers.

Project Need: 5-year maintenance cycle.

Scope: This standard applies to materials, constructions, and testing of 5,000-volt to 46,000-volt shielded crosslinked polyethylene, and ethylene propylene rubber insulated wires and cables that are used for the transmission and distribution of electrical energy for normal conditions of installation and service, either indoors, outdoors, aerial, underground, or submarine.

OPEI (Outdoor Power Equipment Institute)

1605 King Street, 3rd Floor | Alexandria, VA 22314 www.opei.org

Contact: Brandon Martin; bmartin@opei.org

Addenda

BSR/OPEI 60335-2-107 Amd.2-202x, Standard for Outdoor Power Equipment - Household and similar electrical appliances - Safety - Part 2-107: Particular requirements for robotic battery powered electrical lawnmowers (addenda to ANSI/OPEI 60335-2-107-2020)

Stakeholders: General interest, users, producers.

Project Need: The principal objective is to align Clause 22.105.2 with IEC 60335-2-107:2017/AMD2:2021 and address any editorial corrections.

Scope: This is the second proposed amendment to the OPEI 60335-2-107-2020 Amd.1 standard particular requirements for robotic battery-powered electrical lawnmowers that align the standard to IEC 60335-2-107:2017/AMD2:2021. This ANSI/OPEI standard specifies safety requirements and their verification for the design and construction of robotic battery-powered electrical rotary lawnmowers and their peripherals with the rated voltage of the battery being not more than 75V d.c. This standard deals with all the significant hazards presented by battery-powered robotic lawnmowers and their peripherals when they are used as intended and under conditions of misuse which are reasonably foreseeable. This standard also provides requirements for the safety of mains-powered charging stations and signal sources for perimeter delimiters.

SCTE (Society of Cable Telecommunications Engineers)

140 Philips Rd | Exton, PA 19341 www.scte.org

Contact: Kim Cooney; kcooney@scte.org

Reaffirmation

BSR/SCTE 14-2016 (R202x), Test Method for Hex Crimp Tool Verification/Calibration (reaffirmation of ANSI/SCTE 14-2016)

Stakeholders: Cable Telecommunications industry.

Project Need: Update current technology.

Scope: To determine and verify the actual crimp dimension of hex crimp tools. Provide a calibration technique for adjusting hex crimp tools.

SCTE (Society of Cable Telecommunications Engineers)

140 Philips Rd | Exton, PA 19341 www.scte.org

Contact: Kim Cooney; kcooney@scte.org

Revision

BSR/SCTE 25-3-202x, Hybrid Fiber Coax Outside Plant Status Monitoring - Power Supply to Transponder Interface Bus (PSTIB) Specification v1.1 (revision of ANSI/SCTE 25-3-2017)

Stakeholders: Cable Telecommunications industry.

Project Need: Update current technology.

Scope: This specification describes the PSTIB PHY and DLL layer requirements and protocols that must be implemented to support reliable communications between all Type-2- and Type-3-compliant OSP HMS transponders on the HFC plant and managed OSP power supplies and related hardware. Any exceptions to compliance with this specification will be specifically noted in this document as necessary.

SCTE (Society of Cable Telecommunications Engineers)

140 Philips Rd | Exton, PA 19341 www.scte.org

Contact: Kim Cooney; kcooney@scte.org

Reaffirmation

BSR/SCTE 25-1-2017 (R202x), Hybrid Fiber Coax Outside Plant Status Monitoring - Physical (PHY) Layer Specification v1 (reaffirmation of ANSI/SCTE 25-1-2017)

Stakeholders: Cable Telecommunications industry.

Project Need: Update current technology.

Scope: This specification describes the PHY layer requirements that must be implemented by all Type-2- and Type-3-compliant OSP HMS transponders on the HFC plant and the controlling equipment in the headend. Any exceptions to compliance with this specification will be specifically noted in this document as necessary. Refer to Table 1 for a full definition of the Type Classifications.

SCTE (Society of Cable Telecommunications Engineers)

140 Philips Rd | Exton, PA 19341 www.scte.org

Contact: Kim Cooney; kcooney@scte.org

Reaffirmation

BSR/SCTE 25-2-2017 (R202x), Hybrid Fiber Coax Outside Plant Status Monitoring - Media Access Control (MAC) Layer Specification v1.0 (reaffirmation of ANSI/SCTE 25-2-2017)

Stakeholders: Cable Telecommunications industry.

Project Need: Update current technologies.

Scope: This specification describes the MAC layer protocols that must be implemented between all Type-2- and Type-3-compliant OSP HMS transponders on the HFC plant and the controlling equipment in the headend to support bandwidth management and reliable communications. Any exceptions to compliance with this specification will be specifically noted in this document as necessary. Refer to Table 1 for a full definition of the Type Classifications.

SCTE (Society of Cable Telecommunications Engineers)

140 Philips Rd | Exton, PA 19341 www.scte.org

Contact: Kim Cooney; kcooney@scte.org

Revision

BSR/SCTE 45-202x, Test Method for Group Delay (revision of ANSI/SCTE 45-2017)

Stakeholders: Cable Telecommunications industry.

Project Need: Update current technology.

Scope: The purpose of this test is to measure the group delay and group delay variation of a properly terminated device. This procedure is applicable to testing of 75 Ω components.

SCTE (Society of Cable Telecommunications Engineers)

140 Philips Rd | Exton, PA 19341 www.scte.org

Contact: Kim Cooney; kcooney@scte.org

Revision

BSR/SCTE 48-3-202x, Test Procedure for Measuring Shielding Effectiveness of Coaxial Cable and Connectors Using the GTEM Cell (revision of ANSI/SCTE 48-3-2018)

Stakeholders: Cable Telecommunications industry.

Project Need: Update current technology.

Scope: This document details the procedure for measuring the Shielding effectiveness (SE) of coaxial cable and connectors using the gigahertz transverse electromagnetic (GTEM) cell. More particularly, this procedure applies to measuring the S.E. of 75-ohm braided coaxial drop cables and connectors presently used within the broadband communications industry. S.E. measurements can be performed with or without the affixing coaxial connectors removed from the measurement.

SCTE (Society of Cable Telecommunications Engineers)

140 Philips Rd | Exton, PA 19341 www.scte.org

Contact: Kim Cooney; kcooney@scte.org

New Standard

BSR/SCTE 171-202x, Passive Network Device (NID) Enclosure Specification (new standard)

Stakeholders: Cable Telecommunications industry.

Project Need: Update current technology.

Scope: This specification applies to recommended mechanical, electrical, and environmental performance of Network Interface Device enclosures for use in broadband deployment.

SCTE (Society of Cable Telecommunications Engineers)

140 Philips Rd | Exton, PA 19341 www.scte.org

Contact: Kim Cooney; kcooney@scte.org

Revision

BSR/SCTE 240-202x, SCTE Test Procedures for Testing CWDM Systems in Cable Telecommunications Access Networks (revision of ANSI/SCTE 240-2017)

Stakeholders: Cable Telecommunications industry.

Project Need: Update current technology.

Scope: This document describes procedures to support the measurement and characterization of the system optical (loss) performance through the passive points and segments of a Coarse Wavelength Division Multiplexing (CWDM)-based Multi-point Optical Access Network (CWDM-MOAN) fiber cable plant. The procedures contained in this standard are designed to be used in conjunction with the relevant industry test procedures for testing outside plant optical systems.

SCTE (Society of Cable Telecommunications Engineers)

140 Philips Rd | Exton, PA 19341 www.scte.org

Contact: Kim Cooney; kcooney@scte.org

Revision

BSR/SCTE 242-1-202x, Next Generation Audio Coding Constraints for Cable Systems - Part 1: Introduction and Common Constraints (revision of ANSI/SCTE 242-1-2017)

Stakeholders: Cable Telecommunications industry.

Project Need: Update current technology.

Scope: This document is part of a suite documenting coding constraints of Next Generation Audio (NGA) systems for cable television. It is intended to be used in conjunction with the specific audio technologies described in subsequent parts of this standard.

SCTE (Society of Cable Telecommunications Engineers)

140 Philips Rd | Exton, PA 19341 www.scte.org

Contact: Kim Cooney; kcooney@scte.org

Revision

BSR/SCTE 242-2-202x, Next Generation Audio Coding Constraints for Cable Systems - Part 2: AC-4 Audio Coding Constraints (revision of ANSI/SCTE 242-2-2017)

Stakeholders: Cable Telecommunications industry.

Project Need: Update current technology.

Scope: This document is part two of a three-part standard that specifies the coding constraints of Next Generation Audio system for cable television. In conjunction with SCTE 242-1 2017, this document defines the coding constraints on AC-4 for cable television.

SCTE (Society of Cable Telecommunications Engineers)

140 Philips Rd | Exton, PA 19341 www.scte.org

Contact: Kim Cooney; kcooney@scte.org

Revision

BSR/SCTE 242-3-202x, Next Generation Audio Coding Constraints for Cable Systems - Part 3: MPEG-H Audio Coding Constraints (revision of ANSI/SCTE 242-3-2017)

Stakeholders: Cable Telecommunications industry.

Project Need: Update current technology.

Scope: This document is part of a suite documenting coding constraints of Next Generation Audio (NGA) systems for cable television. In conjunction with Part 1 of this standard, it defines the coding constraints on MPEG-H Audio system for cable television.

SCTE (Society of Cable Telecommunications Engineers)

140 Philips Rd | Exton, PA 19341 www.scte.org

Contact: Kim Cooney; kcooney@scte.org

Revision

BSR/SCTE 243-1-202x, Next Generation Audio Carriage Constraints for Cable Systems - Part 1: Common Transport Signaling (revision of ANSI/SCTE 243-1-2017)

Stakeholders: Cable Telecommunications industry.

Project Need: Update current technology.

Scope: This standard is part of a suite documenting carriage constraints of Next Generation Audio (NGA) codecs in MPEG-2 transport systems and in MPEG DASH. It is intended to be used in conjunction with the specific audio technologies described in subsequent parts of this standard.

SCTE (Society of Cable Telecommunications Engineers)

140 Philips Rd | Exton, PA 19341 www.scte.org

Contact: Kim Cooney; kcooney@scte.org

Revision

BSR/SCTE 243-2-202x, Next Generation Audio Carriage Constraints for Cable Systems - Part 2: AC-4 Audio Carriage Constraints (revision of ANSI/SCTE 243-2-2017)

Stakeholders: Cable Telecommunications industry.

Project Need: Update current technology.

Scope: This document is part of a three-part standard that specifies carriage constraints of Next Generation Audio (NGA) codecs in MPEG-2 transport systems and in MPEG DASH. In conjunction with SCTE 243-1 2017, this document defines the carriage of AC-4 audio in MPEG-2 transport systems and MPEG DASH.

SCTE (Society of Cable Telecommunications Engineers)

140 Philips Rd | Exton, PA 19341 www.scte.org

Contact: Kim Cooney; kcooney@scte.org

Revision

BSR/SCTE 243-3-202x, Next Generation Audio Carriage Constraints for Cable Systems - Part 3: MPEG-H Audio Carriage Constraints (revision of ANSI/SCTE 243-3-2017)

Stakeholders: Cable Telecommunications industry.

Project Need: Update current technology.

Scope: This standard is part of a suite documenting carriage constraints of Next Generation Audio (NGA) codecs in MPEG-2 transport systems and in MPEG DASH. This part of the standard, in conjunction with Part 1, defines carriage of MPEG H Audio in MPEG 2 transport systems and in MPEG DASH.

Call for Comment on Standards Proposals

American National Standards

This section solicits public comments on proposed draft new American National Standards, including the national adoption of ISO and IEC standards as American National Standards, and on proposals to revise, reaffirm or withdraw approval of existing American National Standards. A draft standard is listed in this section under the ANSI-accredited standards developer (ASD) that sponsors it and from whom a copy may be obtained. Comments in connection with a draft American National Standard must be submitted in writing to the ASD no later than the last day of the comment period specified herein. Such comments shall be specific to the section (s) of the standard under review and include sufficient detail so as to enable the reader to understand the commenter's position, concerns and suggested alternative language, if appropriate. Please note that the ANSI Executive Standards Council (ExSC) has determined that an ASD has the right to require that interested parties submit public review comments electronically, in accordance with the developer's procedures.

Ordering Instructions for "Call-for-Comment" Listings

1. Order from the organization indicated for the specific proposal.
2. Use the full identification in your order, including the BSR prefix; for example, Electric Fuses BSR/SAE J554.
3. Include remittance with all orders.
4. BSR proposals will not be available after the deadline of call for comment.

Comments should be addressed to the organization indicated, with a copy to the Board of Standards Review, American National Standards Institute, 25 West 43rd Street, New York, NY 10036. e-mail: psa@ansi.org

* Standard for consumer products

Comment Deadline: February 27, 2022

AWI (Architectural Woodwork Institute)

46179 Westlake Drive, Suite 120, Potomac Falls, VA 20165-5874 | cdermyre@awinet.org, www.awinet.org

New Standard

BSR/AWI 0400-202x, Factory Finishing (new standard)

Provide standardized objective criteria for the evaluation of the performance and aesthetic attributes of finish technologies applied to architectural woodwork and related interior products.

[Click here to view these changes in full](#)

Send comments (copy psa@ansi.org) to: <http://gotoawi.com/standards/awi0400.html>

NSF (NSF International)

789 N. Dixboro Road, Ann Arbor, MI 48105-9723 | arose@nsf.org, www.nsf.org

Revision

BSR/NSF 18-202x (i21r1), Manual Food and Beverage Dispensing Equipment (revision of ANSI/NSF 18-2020)

This Standard contains requirements for equipment and devices that manually dispense food or beverages, in bulk or in portions. The materials, design, and construction requirements of this Standard may also be applied to an item that is manufactured as a component of food- and beverage-dispensing equipment. This Standard does not apply to vending machines, dispensing freezers, or bulk milk-dispensing equipment covered by the scope of other NSF Standards.

[Click here to view these changes in full](#)

Send comments (copy psa@ansi.org) to: Allan Rose; arose@nsf.org

Comment Deadline: February 27, 2022

NSF (NSF International)

789 N. Dixboro Road, Ann Arbor, MI 48105-9723 | arose@nsf.org, www.nsf.org

Revision

BSR/NSF 49-202x (i161r1), Biosafety Cabinetry: Design, Construction, Performance, and Field Certification (revision of ANSI/NSF 49-2020)

This Standard applies to Class II (laminar flow) biosafety cabinetry designed to minimize hazards inherent in work with agents assigned to biosafety levels 1, 2, 3, or 4. It also defines the tests that shall be passed by such cabinetry to meet this Standard. This Standard includes basic requirements for the design, construction, and performance of biosafety cabinets (BSCs) that are intended to provide personnel, product, and environmental protection; reliable operation; durability and structural stability; cleanability; limitations on noise level; illumination; vibration; and motor/blower performance.

[Click here to view these changes in full](#)

Send comments (copy psa@ansi.org) to: Allan Rose; arose@nsf.org

NSF (NSF International)

789 N. Dixboro Road, Ann Arbor, MI 48105-9723 | mleslie@nsf.org, www.nsf.org

Revision

BSR/NSF/CAN 372-202x (i6r1), Drinking Water System Components - Lead Content (revision of ANSI/NSF/CAN 372-2020)

This standard establishes procedures for the determination of lead content based on the wetted surface areas of products.

[Click here to view these changes in full](#)

Send comments (copy psa@ansi.org) to: Monica Leslie; mleslie@nsf.org

UL (Underwriters Laboratories)

12 Laboratory Drive, Research Triangle Park, NC 27709-3995 | Vickie.T.Hinton@ul.org, <https://ul.org/>

National Adoption

BSR/UL 60079-47-202x, Standard for Safety for Explosive Atmospheres - Part 47: Equipment Protection by 2-Wire Intrinsically Safe Ethernet Concept (2-WISE) (national adoption with modifications of IEC TS 60079-47)

This proposal provides revisions to the proposal document dated September 24, 2021 as per responses to comments received.

[Click here to view these changes in full](#)

Send comments (copy psa@ansi.org) to: Follow the instructions in the following website to enter comments into the CSDS Work Area: <https://csds.ul.com/Home/ProposalsDefault.aspx>

Comment Deadline: February 27, 2022

UL (Underwriters Laboratories)

12 Laboratory Drive, Research Triangle Park, NC 27709-3995 | Vickie.T.Hinton@ul.org, <https://ul.org/>

Revision

BSR/UL 674-202x, Standard for Safety for Electric Motors and Generators for Use in Division 1 Hazardous (Classified) Locations (revision of ANSI/UL 674-2020)

The following proposals are being provided: (1) Revisions for the use of electronic medium for required documentation; (2) Revisions to include +60°C and -60°C explosion testing with test factors using precompression explosion testing equipment; and (3) Revisions to remove errors and omissions.

[Click here to view these changes in full](#)

Send comments (copy psa@ansi.org) to: Follow the instructions in the following website to enter comments into the CSDS Work Area: <https://csds.ul.com/Home/ProposalsDefault.aspx>

UL (Underwriters Laboratories)

12 Laboratory Drive, Research Triangle Park, NC 27709-3995 | Jonette.A.Herman@ul.org, <https://ul.org/>

Revision

BSR/UL 1004-10-202x, Standard for Pool Pump Motors (revision of ANSI/UL 1004-10-2020)

The following is proposed: Addition of glossary term for "Factory Default Setting".

[Click here to view these changes in full](#)

Send comments (copy psa@ansi.org) to: Follow the instructions in the following website to enter comments into the CSDS Work Area: <https://csds.ul.com/Home/ProposalsDefault.aspx>

UL (Underwriters Laboratories)

333 Pfingsten Road, Northbrook, IL 60062 | Elizabeth.Northcott@ul.org, <https://ul.org/>

Revision

BSR/UL 1678-202x, Standard for Household, Commercial, and Institutional-Use Carts, Stands and Entertainment Centers for Use with Audio and/or Video Equipment (revision of ANSI/UL 1678-2019)

(1) Proposed revisions to Paragraph 11.1.1 to specify that flammability ratings for polymeric parts are required only when the parts are used for support or enclosure of live parts.

[Click here to view these changes in full](#)

Send comments (copy psa@ansi.org) to: Follow the instructions in the following website to enter comments into the CSDS Work Area: <https://csds.ul.com/Home/ProposalsDefault.aspx>

UL (Underwriters Laboratories)

333 Pfingsten Road, Northbrook, IL 60062-2096 | Heather.Sakellariou@ul.org, <https://ul.org/>

Revision

BSR/UL 4600-202x, Standard for Safety for the Evaluation of Autonomous Products (revision of ANSI/UL 4600-2020)

The following is being recirculated for your review: (1) Revise requirements regarding safety case (Section 5); (3) Revise requirements in assessment (Section 3).

[Click here to view these changes in full](#)

Send comments (copy psa@ansi.org) to: Follow the instructions in the following website to enter comments into the CSDS Work Area: <https://csds.ul.com/Home/ProposalsDefault.aspx>

Comment Deadline: March 14, 2022

AAFS (American Academy of Forensic Sciences)

410 North 21st Street, Colorado Springs, CO 80904 | tambrosius@aafs.org, www.aafs.org

New Standard

BSR/ASB BPR 165-202x, Best Practice Recommendation for Analysis of Friction Ridge Impressions (new standard)

This document provides best practice recommendations for the analysis of friction ridge impressions as part of the analysis, comparison, and evaluation examination methodology. These recommendations include how to assess, document the quality of friction ridge detail and categorize impressions on the basis of their complexity, and document the utility of impressions for further examination. This document does not address the comparison or evaluation stages of the friction ridge examination methodology.

Single copy price: Free

Obtain an electronic copy from: Document and comments template can be viewed on the AAFS Standards Board website at: <http://www.asbstandardsboard.org/notice-of-standard-development-and-coordination//>

Order from: Document will be provided electronically on AAFS Standards Board website (www.asbstandardsboard.org) free of charge.

Send comments (copy psa@ansi.org) to: asb@aafs.org

AAFS (American Academy of Forensic Sciences)

410 North 21st Street, Colorado Springs, CO 80904 | tambrosius@aafs.org, www.aafs.org

New Standard

BSR/ASB BPR 166-202x, Best Practice Recommendation for Comparison and Evaluation of Friction Ridge Impressions (new standard)

This document provides best practice recommendations for the comparison and evaluation of friction ridge impressions as part of the analysis, comparison, and evaluation examination methodology. These recommendations include how to categorize comparisons between two friction ridge impressions on the basis of their complexity and specifies the criteria for supporting Source Conclusions. This document does not address the analysis stage of the friction ridge examination methodology.

Single copy price: Free

Obtain an electronic copy from: Document and comments template can be viewed on the AAFS Standards Board website at: <http://www.asbstandardsboard.org/notice-of-standard-development-and-coordination//>

Order from: Document will be provided electronically on AAFS Standards Board website (www.asbstandardsboard.org) free of charge.

Send comments (copy psa@ansi.org) to: asb@aafs.org

Comment Deadline: March 14, 2022

AAFS (American Academy of Forensic Sciences)

410 North 21st Street, Colorado Springs, CO 80904 | tambrosius@aafs.org, www.aafs.org

New Standard

BSR/ASB Std 145-202x, Standard for Consultation during Friction Ridge Examination (new standard)

This standard sets documentation, quality, and consultant requirements for consultations during Friction Ridge examinations. This document does not apply to conflict resolution.

Single copy price: Free

Obtain an electronic copy from: This is a public comment period for a recirculation. Updated document, redline version, and comments can be viewed on the AAFS Standards Board website at: <http://www.asbstandardsboard.org/notice-of-standard-development-and-coordination/>.

Order from: Document will be provided electronically on AAFS Standards Board website (www.asbstandardsboard.org) free of charge.

Send comments (copy psa@ansi.org) to: asb@aafs.org

AAMI (Association for the Advancement of Medical Instrumentation)

901 N. Glebe Road, Suite 300, Arlington, VA 22203 | abenedict@aami.org, www.aami.org

National Adoption

BSR/AAMI/ISO 17664-1-202x, Processing of health care products - Information to be provided by the medical device manufacturer for the processing of medical devices - Part 1: Critical and semi-critical medical devices (identical national adoption of ISO 17664-1:2021 and revision of ANSI/AAMI/ISO 17664-2017)

Specifies requirements for the information to be provided by the medical device manufacturer for the processing of a medical device that requires sterilization or disinfection to ensure that the device is safe and effective for its intended use. This includes information for processing prior to use or reuse of the medical device. Applicable for medical devices that are intended for invasive or other direct patient contact or that otherwise present the risk of transmission of infectious agents. Processing instructions are not defined in this standard. Rather, this International Standard specifies requirements to assist manufacturers of medical devices in providing detailed instructions for processing that consists of the following activities where applicable: pre-treatment at the point of use; preparation, cleaning, disinfection; drying; inspection, maintenance, and testing; packaging; sterilization; storage; and transportation.

Single copy price: Free

Obtain an electronic copy from: abenedict@aami.org

Send comments (copy psa@ansi.org) to: Amanda Benedict; abenedict@aami.org

AAMI (Association for the Advancement of Medical Instrumentation)

901 N. Glebe Road, Suite 300, Arlington, VA 22203 | abenedict@aami.org, www.aami.org

National Adoption

BSR/AAMI/ISO 17664-2-202x, Processing of health care products - Information to be provided by the medical device manufacturer for the processing of medical devices - Part 2: Non-critical medical devices (identical national adoption of ISO 17664-2:2021)

Specifies requirements for the information to be provided by the medical device manufacturer for the processing of non-critical medical devices not intended to be sterilized (i.e., a medical device that is intended to come into contact with intact skin only or a medical device not intended for direct patient contact). This includes information for processing prior to use or reuse of the medical device.

Single copy price: Free

Obtain an electronic copy from: abenedict@aami.org

Send comments (copy psa@ansi.org) to: abenedict@aami.org

Comment Deadline: March 14, 2022

ACI (American Concrete Institute)

38800 Country Club Drive, Farmington Hills, MI 48331 | shannon.banchero@concrete.org, www.concrete.org

New Standard

BSR/ACI CODE-437.2-202x, Load Testing of Concrete Structures - Code Requirements and Commentary (new standard)

This code provides requirements for test load magnitudes, test protocols, and acceptance criteria for conducting a load test as a means of evaluating the safety and serviceability of concrete structural members and systems of structures. A load test may be conducted as part of a structural evaluation to determine whether a structure requires repair and rehabilitation, or to verify the adequacy of repair and rehabilitation measures.

Single copy price: Free

Obtain an electronic copy from: <https://www.concrete.org/publications/standards/upcomingstandards.aspx>

Order from: Shannon Banchero; shannon.banchero@concrete.org

Send comments (copy psa@ansi.org) to: Same

ACP (American Clean Power Association)

1501 M Street NW, Suite 900, Washington, DC 20005 | standards@cleanpower.org, www.cleanpower.org

New Standard

BSR/ACP 1000-2.1-202x, Definitions and Nomenclatures (new standard)

This standard identifies the set of definitions used within the American wind energy industry when defining training requirements for fall protection and rescue in wind turbines.

Single copy price: \$Draft is available free of charge

Obtain an electronic copy from: <https://cleanpower.org/standards-development/>

Send comments (copy psa@ansi.org) to: standards@cleanpower.org

ACP (American Clean Power Association)

1501 M Street NW, Suite 900, Washington, DC 20005 | standards@cleanpower.org, www.cleanpower.org

New Standard

BSR/ACP 1000-2.2-202x, Rescue Training Requirements (new standard)

This standard identifies the recommended minimum training guidelines for persons rescuing in wind turbines and associated structures within the American wind energy industry.

Single copy price: \$Draft is available free of charge

Obtain an electronic copy from: <https://cleanpower.org/standards-development/>

Send comments (copy psa@ansi.org) to: standards@cleanpower.org

ACP (American Clean Power Association)

1501 M Street NW, Suite 900, Washington, DC 20005 | standards@cleanpower.org, www.cleanpower.org

New Standard

BSR/ACP 1000-2.3-202x, Fall Protection Training Requirements (new standard)

This standard identifies the minimum training guidelines for persons climbing wind turbines and associated structures within the American wind energy industry.

Single copy price: \$Draft is available free of charge

Obtain an electronic copy from: <https://cleanpower.org/standards-development/>

Send comments (copy psa@ansi.org) to: standards@cleanpower.org

Comment Deadline: March 14, 2022

ADA (American Dental Association)

211 East Chicago Avenue, Chicago, IL 60611-2678 | bralowerp@ada.org, www.ada.org

New Standard

BSR/ADA Standard No. 1105-202x, Digital Periodontitis Risk Assessment Resources (new standard)

The purpose of this document is to describe the essential characteristics for digital periodontitis risk assessment resources including standardized definitions, description of input elements, and components and characteristics of a periodontitis risk assessment report.

Single copy price: \$25.00

Obtain an electronic copy from: standards@ada.org

Order from: Paul Bralower; bralowerp@ada.org

Send comments (copy psa@ansi.org) to: Same

ASC X9 (Accredited Standards Committee X9, Incorporated)

275 West Street, Suite 107, Annapolis, MD 21401 | Ambria.frazier@x9.org, www.x9.org

National Adoption

BSR X9.134-3-202x, Mobile Financial Services - Part 3: Financial Application Lifecycle and Management (national adoption with modifications of ISO 12812)

Part 3 of the suite of standards for mobile banking/payments will include specific requirements applicable to all mobile financial service providers (MFSPs) detailing the approach to a secure deployment and operation of an MFS application throughout the various phases of its lifecycle (e.g., subscription, installation, usage, and termination) in order to facilitate and promote interoperability, security, and quality of MFS services throughout the U.S.

Single copy price: \$65.00

Obtain an electronic copy from: ambria.frazier@x9.org

Order from: Ambria Frazier; Ambria.frazier@x9.org

Send comments (copy psa@ansi.org) to: Same

ASC X9 (Accredited Standards Committee X9, Incorporated)

275 West Street, Suite 107, Annapolis, MD 21401 | Ambria.frazier@x9.org, www.x9.org

National Adoption

BSR X9.134-4-202x, Core Banking: Mobile Financial Services - Part 4: Mobile Payments-to-Persons (national adoption with modifications of ISO 12812 Part 4)

Part 4 of the suite of standards for mobile banking/payments will include specific requirements applicable to all mobile financial service providers (MFSPs) detailing requirements, recommendations, and guidance for offering MFSs for mobile payments to persons.

Single copy price: \$175.00

Obtain an electronic copy from: ambria.frazier@x9.org

Order from: Ambria Frazier; Ambria.frazier@x9.org

Send comments (copy psa@ansi.org) to: Same

Comment Deadline: March 14, 2022

ASHRAE (American Society of Heating, Refrigerating and Air-Conditioning Engineers, Inc.)

180 Technology Parkway, Peachtree Corners, GA 30092 | cking@ashrae.org, www.ashrae.org

A call for comment was mistakenly announced last week, ahead of schedule. The comment period will begin Jan-28, 2022, and will end Mar-14, 2022.

New Standard

BSR/ASHRAE Standard 228-202x, Standard Method for Evaluating Zero Net Energy and Zero Net Carbon Building Performance (new standard)

ASHRAE Standard 228-202x sets requirements for evaluating whether a building or group of buildings meets a definition of “zero net energy” or whether those buildings meet a definition of “zero net carbon.” It provides a consistent method of expressing qualifications for zero net energy and zero net carbon buildings associated with the design of new buildings and the operation of existing buildings.

Single copy price: \$35.00

Obtain an electronic copy from: <http://www.ashrae.org/standards-research--technology/public-review-drafts>

Order from: standards.section@ashrae.org

Send comments (copy psa@ansi.org) to: <http://www.ashrae.org/standards-research--technology/public-review-drafts>

AWWA (American Water Works Association)

6666 W. Quincy Avenue, Denver, CO 80235 | polson@awwa.org, www.awwa.org

Revision

BSR/AWWA G300-202x, Source Water Protection (revision of ANSI/AWWA G300-2014)

This standard describes the essential elements for the effective protection of source waters.

Single copy price: Free

Obtain an electronic copy from: ETSupport@awwa.org

Order from: AWWA, Vicki David; vdavid@awwa.org

Send comments (copy psa@ansi.org) to: AWWA, Paul Olson; polson@awwa.org

CSA (CSA America Standards Inc.)

8501 East Pleasant Valley Road, Cleveland, OH 44131-5575 | ansi.contact@casgroup.org, www.casgroup.org

New Standard

BSR Z21.85-202x, Alternative connection means for use in gas appliances (new standard)

This Standard applies to internal quick fastener connection for gas appliances, referred to as an alternative connection means (ACM) in this standard, constructed entirely of new, unused parts and materials. ACM are limited in size up to and including NPS 1 in (DN 25) diameter and a maximum pressure of up to and including 1/2 psi (3.5 kPa). This Standard applies to ACM that are intended for the quick assembly of the gas train (i.e., controls and piping) inside an appliance, which is assembled by the appliance manufacturer. ACM are not intended for the direct connection of the appliance to the fuel supply.

Single copy price: Free

Obtain an electronic copy from: ansi.contact@casgroup.org

Send comments (copy psa@ansi.org) to: ansi.contact@casgroup.org

Comment Deadline: March 14, 2022

HL7 (Health Level Seven)

3300 Washtenaw Avenue, Suite 227, Ann Arbor, MI 48104 | Karenvan@HL7.org, www.hl7.org

Reaffirmation

BSR/HL7 EHRRXPROVFP, R1-2012 (R202x), HL7 EHR-System Pharmacist/Pharmacy Provider Functional Profile, Release 1- US Realm (reaffirmation of ANSI/HL7 EHRRXPROVFP, R1-2012 (R2017))

The Pharmacist/Pharmacy Provider Functional Profile will facilitate EHR systems capture of medication and clinical related data at the point of contact or point of care by specifying the functional requirements needed to support messaging among prescribers, pharmacist and pharmacy providers, and other health care entities needing medication-related information.

Single copy price: Free to members and non-members

Obtain an electronic copy from: Karenvan@HL7.org

Order from: Karen Van Hentenryck; Karenvan@HL7.org

Send comments (copy psa@ansi.org) to: Same

ICC (International Code Council)

4051 Flossmoor Road, Country Club Hills, IL 60478 | kaittaniemi@iccsafe.org, www.iccsafe.org

Revision

BSR/ICC 500-202x, ICC/NSSA Standard for the Design and Construction of Storm Shelters (revision of ANSI/ICC 500-2020)

The objective of this Standard is to provide technical design and performance criteria that will facilitate and promote the design, construction, and installation of safe, reliable, and economical storm shelters to protect the public. It is intended that this Standard be used by design professionals; storm shelter designers, manufacturers, and constructors; building officials; emergency management personnel, and government officials to ensure that storm shelters provide a consistently high level of protection to the sheltered public.

Single copy price: Free

Obtain an electronic copy from: <https://codes.iccsafe.org/codes/icc-standards>

Send comments (copy psa@ansi.org) to: kpaarlberg@iccsafe.org

NECA (National Electrical Contractors Association)

1201 Pennsylvania Avenue, Suite 1200, Washington, DC 20004 | Aga.golriz@necanet.org, www.neca-neis.org

New Standard

BSR/NECA 5-202X, Recommended Practice for Prefabrication of Electrical Installations for Construction (new standard)

This standard describes recommended on-site and off-site practices for prefabrication of electrical installations for construction projects. The term "prefabrication" collectively refers to any kind of completion of electrical components, (sub-) assemblies, or modules of a construction project that is taken from the final point of installation to a different, off-site location and performed in a controlled environment.

Single copy price: \$30.00 (NECA members);\$60.00 (non-members)

Obtain an electronic copy from: neis@necanet.org

Order from: neis@necanet.org

Send comments (copy psa@ansi.org) to: neis@necanet.org or aga.golriz@necanet.org

Comment Deadline: March 14, 2022

NFPA (National Fire Protection Association)

One Batterymarch Park, Quincy, MA 02169 | dbellis@nfpa.org, www.nfpa.org

NFPA FIRE PROTECTION STANDARDS DOCUMENTATION

*The National Fire Protection Association announces the availability of the NFPA Second Draft Report for concurrent review and comment by NFPA and ANSI. These Second Draft Reports contain the disposition of public comment(s) that were received for standards in the Annual 2022 Revision Cycle (available for review on the next edition tab for each standard). All Notices of Intent to Make A Motion on the A2022 Revision Cycle Second Draft Report must be received by the following date: **February 22, 2022**.*

For more information on the rules and deadlines for NFPA standards in cycle, please check the NFPA website (www.nfpa.org) or contact Standards Administration at NFPA. Those who submit comments to NFPA's online submission system on the A2022 Revision Cycle Standards are invited to copy ANSI's Board of Standards Review.

New Standard

BSR/NFPA 715-202x, Standard for the Installation of Fuel Gases Detection and Warning Equipment (new standard)

This standard shall be concerned with life safety and protection of property. This standard shall cover the selection, design, application, installation, location, performance, inspection, testing, and maintenance of fuel gas detection and warning equipment in buildings and structures. This standard shall contain requirements for the selection, installation, operation, and maintenance of equipment that detects concentrations of fuel gases that could pose a life or property safety risk.

Obtain an electronic copy from: www.nfpa.org/715Next

Send comments (copy psa@ansi.org) to: Same

NFPA (National Fire Protection Association)

One Batterymarch Park, Quincy, MA 02169 | dbellis@nfpa.org, www.nfpa.org

Revision

BSR/NFPA 51-202x, Standard for the Design and Installation of Oxygen-Fuel Gas Systems for Welding, Cutting, and Allied Processes (revision of ANSI/NFPA 51-2017)

1.1 Scope. 1.1.1 This standard applies to the following: (1) Design and installation of oxygen–fuel gas welding and cutting systems and allied processes, except for systems meeting the criteria in 1.1.5; (2) Utilization of gaseous fuels generated from flammable liquids under pressure where such fuels are used with oxygen; (3) Storage on the site of a welding and cutting system installation of the following: (a) Gases to be used with such systems where more than one cylinder each of oxygen and fuel gas are stored in any single storage area [includes storage of more than one cylinder each in any single storage area even though all such stored cylinders may be intended for use in systems of the kind described in 1.1.5(1)]; (b) Calcium carbide. 1.1.2 Unless specifically indicated otherwise, the term “welding and cutting systems” shall be considered to include allied processes in this standard. 1.1.3 Where only a portion of a fuel gas system is to be used for welding, cutting, or allied processes, only that portion of the system need comply with this standard. 1.1.4 Where only a portion of an oxygen system is to be used with fuel gas for welding...

Obtain an electronic copy from: www.nfpa.org/51Next

Send comments (copy psa@ansi.org) to: Same

Comment Deadline: March 14, 2022

NFPA (National Fire Protection Association)

One Batterymarch Park, Quincy, MA 02169 | dbellis@nfpa.org, www.nfpa.org

Revision

BSR/NFPA 750-202x, Standard on Water Mist Fire Protection Systems (revision of ANSI/NFPA 750-2019)

This standard contains the minimum requirements for the design, installation, maintenance, and testing of water-mist fire-protection systems. This standard does not provide definitive fire performance criteria, nor does it offer specific guidance on how to design a system to control, suppress, or extinguish a fire. Reliance is placed on the procurement and installation of listed water-mist equipment or systems that have demonstrated performance in fire tests as part of a listing process. Other NFPA standards should be referenced for additional requirements relating to underground or lead-in connections to water-mist systems from municipal or private water supplies.

Obtain an electronic copy from: www.nfpa.org/750Next

Send comments (copy psa@ansi.org) to: Same

NFPA (National Fire Protection Association)

One Batterymarch Park, Quincy, MA 02169 | dbellis@nfpa.org, www.nfpa.org

Revision

BSR/NFPA 780-202x, Standard for the Installation of Lightning Protection Systems (revision of ANSI/NFPA 780-2020)

This document shall cover traditional lightning protection system installation requirements for the following: (1) Ordinary structures; (2) Miscellaneous structures and special occupancies; (3) Heavy-duty stacks; (4) Structures containing flammable vapors, flammable gases, or liquids that can give off flammable vapors; (5) Structures housing explosive materials; (6) Wind turbines; (7) Watercraft; (8) Airfield lighting circuits; and (9) Solar arrays. This document shall address lightning protection of the structure but not the equipment or installation requirements for electric generating, transmission, and distribution systems except as given in Chapter 9 and Chapter 12.

Obtain an electronic copy from: www.nfpa.org/780Next

Send comments (copy psa@ansi.org) to: Same

NSF (NSF International)

789 N. Dixboro Road, Ann Arbor, MI 48105-9723 | jsnider@nsf.org, www.nsf.org

Revision

BSR/NSF/CAN 50-202x (i140r5), Spas, Hot Tubs and Other Recreational Water Facilities (revision of ANSI/NSF/CAN 50-2020)

This Standard covers materials, chemicals, components, products, equipment, and systems, related to public and residential recreational water facility operation.

Single copy price: Free

Obtain an electronic copy from: https://standards.nsf.org/apps/group_public/download.php/62125/50i140r5%20-%20Regenerative%20Media%20PBT%20-%20JC%20memo%20&%20ballot.pdf

Send comments (copy psa@ansi.org) to: Jason Snider; jsnider@nsf.org

Comment Deadline: March 14, 2022

SCTE (Society of Cable Telecommunications Engineers)

140 Philips Rd, Exton, PA 19341 | kcooney@scte.org, www.scte.org

New Standard

BSR/SCTE 275-202x, Electrical Grounding and Bonding for Cable Broadband Network Critical Facilities (new standard)

This document includes practices for exterior-system grounding and bonding, interior grounding systems, surge protection, roof-mounted lightning protection, environmental handling for electric static discharge (ESD)-sensitive equipment, commissioning, and maintenance.

Single copy price: \$50.00

Obtain an electronic copy from: admin@standards.scte.org

Send comments (copy psa@ansi.org) to: admin@standards.scte.org

SCTE (Society of Cable Telecommunications Engineers)

140 Philips Rd, Exton, PA 19341 | kcooney@scte.org, www.scte.org

Reaffirmation

BSR/SCTE 159-1-2017 (R202x), Multimedia Application and Service - Part 1: IPCablecom Multimedia (reaffirmation of ANSI/SCTE 159-1-2017)

As outlined in the accompanying technical report, the current scope of this standard is limited to network-based QoS resource management and usage auditing capabilities. This approach was motivated by several criteria, including rapid time-to-market for QoS-enhanced Multimedia services (which may take the form of new applications or existing applications retrofitted per this standard), the absence of QoS signaling requirements on CPE devices, and security assurances provided by an absence of client-based QoS signaling.

Single copy price: \$50.00

Obtain an electronic copy from: admin@standards.scte.org

Order from: Global Engineering Documents, (800) 854-7179, www.global.ihs.com

Send comments (copy psa@ansi.org) to: admin@standards.scte.org

SCTE (Society of Cable Telecommunications Engineers)

140 Philips Rd, Exton, PA 19341 | kcooney@scte.org, www.scte.org

Reaffirmation

BSR/SCTE 159-2-2017 (R202x), Multimedia Application and Service - Part 2: IPCablecom Multimedia Web Services (reaffirmation of ANSI/SCTE 159-2-2017)

This specification provides a simple, open interface between a generic Application Server (AS) and an IPCablecom Multimedia Application Manager (AM). Specifically, this specification defines a common Web Service (WS) interface to the IPCablecom Multimedia Application Manager (AM) that enables an AS to dynamically request network resources on the cable operator's access network. The primary goal of this interface is to allow AS developers to rapidly create new applications in shorter timeframes and without having a deep knowledge of the cable operator's access technology. This interface is based on the SOAP/eXtensible Markup Language (SOAP/XML).

Single copy price: \$50.00

Obtain an electronic copy from: admin@standards.scte.org

Order from: Global Engineering Documents, (800) 854-7179, www.global.ihs.com

Send comments (copy psa@ansi.org) to: admin@standards.scte.org

Comment Deadline: March 14, 2022

TAPPI (Technical Association of the Pulp and Paper Industry)

15 Technology Parkway, Suite 115, Peachtree Corners, GA 30092 | standards@tappi.org, www.tappi.org

New Standard

BSR/TAPPI T 211 om-202x, Ash in wood, pulp, paper and paperboard: combustion at 525C (new standard)

This method for determination of ash can be applied to all types and grades of wood pulp paper, and paper products. For the determination of ash by combustion at 900 C, see TAPPI T 413, "Ash in Wood, Pulp, Paper and Paperboard: Combustion at 900 C."

Single copy price: Free

Obtain an electronic copy from: standards@tappi.org

Order from: standards@tappi.org

Send comments (copy psa@ansi.org) to: Natasha Bush-Postell, standards@tappi.org

TAPPI (Technical Association of the Pulp and Paper Industry)

15 Technology Parkway, Suite 115, Peachtree Corners, GA 30092 | standards@tappi.org, www.tappi.org

New Standard

BSR/TAPPI T 252 om-202x, pH and electrical conductivity of hot water extracts of pulp, paper, and paperboard (new standard)

This procedure provides for the extraction of pulp, paper, and paperboard samples using boiling reagent water followed by determination of the pH and conductivity of the extract.

Single copy price: Free

Obtain an electronic copy from: standards@tappi.org

Order from: standards@tappi.org

Send comments (copy psa@ansi.org) to: Natasha Bush-Powell, standards@tappi.org

TAPPI (Technical Association of the Pulp and Paper Industry)

15 Technology Parkway, Suite 115, Peachtree Corners, GA 30092 | standards@tappi.org, www.tappi.org

New Standard

BSR/TAPPI T 400 sp-202x, Sampling and accepting a single lot of paper, paperboard, containerboard, or related product (new standard)

This method describes procedures for obtaining a representative sample for testing. It should be recognized that in an ideal situation the samples selected should represent a lot of paper or paperboard, container board, or related product, including converted paper products (all referred to as "paper" in this standard). However, in some situations, the sample may be as small as a single sheet of paper that has been provided to the laboratory for testing and may not represent the lot from which it is obtained.

Single copy price: Free

Obtain an electronic copy from: standards@tappi.org

Order from: standards@tappi.org

Send comments (copy psa@ansi.org) to: Natasha Bush-Postell, standards@tappi.org

Comment Deadline: March 14, 2022

TAPPI (Technical Association of the Pulp and Paper Industry)

15 Technology Parkway, Suite 115, Peachtree Corners, GA 30092 | standards@tappi.org, www.tappi.org

New Standard

BSR/TAPPI T 412 om-202x, Moisture in pulp, paper and paperboard (new standard)

The following procedure applies to pulp, paper, paperboard, and paper products, except those containing significant quantities of materials other than water that are volatile at lower than 107°C (224.6°F) or degrade above 103°C (217.4°F). Moisture is significant for economic reasons and for its effect on such properties as printability, shrinkage, dimensional stability, physical strength, and paper runnability. This method should be followed to: (1) Determine the amount of moisture in a lot of pulp, paper, or paperboard as an “as received” moisture; (2) Determine the amount of moisture in shipping containers; and (3) Calculate results of the analysis of the moisture content on the original weight of the specimen.

Single copy price: Free

Obtain an electronic copy from: standards@tappi.org

Order from: standards@tappi.org

Send comments (copy psa@ansi.org) to: Natasha Bush-Postell, standards@tappi.org

TAPPI (Technical Association of the Pulp and Paper Industry)

15 Technology Parkway, Suite 115, Peachtree Corners, GA 30092 | standards@tappi.org, www.tappi.org

New Standard

BSR/TAPPI T 435 om-202x, Hydrogen ion concentration (pH) of paper extracts (hot extraction method) (new standard)

This method measures the hydrogen ion concentration, expressed in terms of pH, of an aqueous extract of paper obtained by hot extraction (unfiltered and extracted by boiling water for one hour). It may be applied to writing, printing, and sized industrial paper, but it is not intended for unbuffered types such as electrical insulating and condenser papers. Values determined by this method will reflect changes resulting from heat-induced hydrolysis. Additives, such as those used in filled and coated papers can have an effect on the extract pH. The cold extraction method is described in TAPPI T 509, “Hydrogen Ion Concentration (pH) of Paper Extracts (Cold Extraction Method).” Surface pH measurement of paper is described in TAPPI T 529, “Surface pH Measurement of Paper.”

Single copy price: Free

Obtain an electronic copy from: standards@tappi.org

Order from: standards@tappi.org

Send comments (copy psa@ansi.org) to: Natasha Bush-Powell, standards@tappi.org

Comment Deadline: March 14, 2022

TAPPI (Technical Association of the Pulp and Paper Industry)

15 Technology Parkway, Suite 115, Peachtree Corners, GA 30092 | standards@tappi.org, www.tappi.org

New Standard

BSR/TAPPI T 509 om-202x, Hydrogen ion concentration (pH) of paper extracts (cold extraction method) (new standard)

This method measures the hydrogen ion concentration of a cold aqueous extract (unfiltered) of paper, expressed in terms of pH value. It is suitable for writing, printing, and sized industrial papers, but is not intended for unbuffered types such as insulating and condenser papers. The determined values may not be exact in a fundamental sense and should not be interpreted in terms of solution theory. The pH values are empirically correlated with end-use requirements and paper qualities. This method avoids change of acidity or alkalinity resulting from heat-induced hydrolysis. A hot-water extraction method is described in TAPPI T 435, "Hydrogen Ion Concentration (pH) of Paper Extracts (Hot Extraction Method)." Surface pH measurement of paper is described in TAPPI T 529, "Surface pH Measurement of Paper."

Single copy price: Free

Obtain an electronic copy from: standards@tappi.org

Order from: standards@tappi.org

Send comments (copy psa@ansi.org) to: Natasha Bush-Powell, standards@tappi.org

TAPPI (Technical Association of the Pulp and Paper Industry)

15 Technology Parkway, Suite 115, Peachtree Corners, GA 30092 | standards@tappi.org, www.tappi.org

New Standard

BSR/TAPPI T 538 om-202x, Roughness of paper and paperboard (Sheffield method) (new standard)

This method is a measurement of the air flow between the specimen (backed by flat glass on the bottom side) and two pressurized, concentric annular lands that are impressed into the sample from the top side. The rate of air flow is related to the surface roughness of paper or paperboard.

Single copy price: Free

Obtain an electronic copy from: standards@tappi.org

Order from: standards@tappi.org

Send comments (copy psa@ansi.org) to: Natasha Bush-Postell, standards@tappi.org

TAPPI (Technical Association of the Pulp and Paper Industry)

15 Technology Parkway, Suite 115, Peachtree Corners, GA 30092 | standards@tappi.org, www.tappi.org

New Standard

BSR/TAPPI T 543 om-202x, Bending resistance of paper (Gurley-type tester) (new standard)

This procedure determines the bending resistance of paper, paperboard, and other materials by measuring the force required to bend a specimen under controlled conditions. The instrument described allows for a wide variation in specimen length and width, and in applied force. This procedure is not recommended for soft or limp materials such as tissue, toweling, and newsprint, or for materials with a pronounced degree of curl.

Single copy price: Free

Obtain an electronic copy from: standards@tappi.org

Order from: standards@tappi.org

Send comments (copy psa@ansi.org) to: Natasha Bush-Postell, standards@tappi.org

Comment Deadline: March 14, 2022

TAPPI (Technical Association of the Pulp and Paper Industry)

15 Technology Parkway, Suite 115, Peachtree Corners, GA 30092 | standards@tappi.org, www.tappi.org

New Standard

BSR/TAPPI T 610 sp-202x, Preparation of indicators and standard solutions (new standard)

This method describes preparation of frequently used indicator solutions and preparation and standardization of frequently used volumetric reagent solutions (usually called “standard solutions”) required in TAPPI Test Methods.

Single copy price: Free

Obtain an electronic copy from: standards@tappi.org

Order from: standards@tappi.org

Send comments (copy psa@ansi.org) to: Natasha Bush-Powell, standards@tappi.org

TAPPI (Technical Association of the Pulp and Paper Industry)

15 Technology Parkway, Suite 115, Peachtree Corners, GA 30092 | standards@tappi.org, www.tappi.org

New Standard

BSR/TAPPI T 646 om-202x, Brightness of clay and other mineral pigments (45/0) (new standard)

This method describes a procedure for determining the brightness of clay or other mine pigment that has been pulverized under controlled conditions and made into a uniform compacted pigment plaque. This method is for use with minerals normally used in the manufacture of paper and is not intended for highly colored pigments.

Single copy price: Free

Obtain an electronic copy from: standards@tappi.org

Order from: standards@tappi.org

Send comments (copy psa@ansi.org) to: Natasha Bush-Postell, standards@tappi.org

TAPPI (Technical Association of the Pulp and Paper Industry)

15 Technology Parkway, Suite 115, Peachtree Corners, GA 30092 | standards@tappi.org, www.tappi.org

New Standard

BSR/TAPPI T 684 om-202x, Gross heating value of black liquor (new standard)

This method determines the gross (or high) heating value of black liquor, containing up to 55% by mass of water, derived from sodium-based kraft pulping. The products of combustion in the recovery furnace are different from the bomb calorimeter products because of the reducing atmosphere which exists in the hearth zone of the furnace. A “heat of reaction correction” based on an elemental analysis of the waste liquor sample should be used to account for this difference. It is described in a TAPPI Steam and Power Committee Technical Information Sheet for calculation of recovery unit performance (TIP 0416-01 “Recovery Boiler Performance Calculation - Short Form”).

Single copy price: Free

Obtain an electronic copy from: standards@tappi.org

Order from: standards@tappi.org

Send comments (copy psa@ansi.org) to: Natasha Bush-Postell, standards@tappi.org

Comment Deadline: March 14, 2022

TAPPI (Technical Association of the Pulp and Paper Industry)

15 Technology Parkway, Suite 115, Peachtree Corners, GA 30092 | standards@tappi.org, www.tappi.org

New Standard

BSR/TAPPI T 1009 om-202x, Tensile strength and elongation at break for fiber glass mats (new standard)

This method covers the determination of the tensile strength and elongation at break of fiber glass mats.

Single copy price: Free

Obtain an electronic copy from: standards@tappi.org

Order from: standards@tappi.org

Send comments (copy psa@ansi.org) to: Natasha Bush-Postell, standards@tappi.org

TAPPI (Technical Association of the Pulp and Paper Industry)

15 Technology Parkway, Suite 115, Peachtree Corners, GA 30092 | standards@tappi.org, www.tappi.org

Reaffirmation

BSR/TAPPI T 268 om-2013 (R202x), Weight-volume measurement of pulpwood (reaffirmation of ANSI/TAPPI T 268 om-2013)

A method is described for determining the weight of pulpwood per unit of volume (a standard racked cord). The determination in this method refers to an ideally racked cord, which usually is not identical to commercially scaled wood, because: (1) There is always a change in apparent volume after sawing longer lengths into shorter lengths and repiling; (2) The voids along the sides and bottom of the cord as racked experimentally are partly filled in the ordinary scaled cord; (3) Shaking and jolting during shipment (if the scaling is done at the unloading terminal) normally cause the wood to settle more compactly. This method will also provide data on the gross weight of wood in a cord; the average, maximum, and minimum diameters of bark-free logs; percentage bark by green weight and volume; average length of logs; moisture content; density; solid wood volume; and the total oven-dry weight of bark-free wood per cord.

Single copy price: Free

Obtain an electronic copy from: standards@tappi.org

Order from: standards@tappi.org

Send comments (copy psa@ansi.org) to: Natasha Bush-Postell, standards@tappi.org

TAPPI (Technical Association of the Pulp and Paper Industry)

15 Technology Parkway, Suite 115, Peachtree Corners, GA 30092 | standards@tappi.org, www.tappi.org

Reaffirmation

BSR/TAPPI T 546 om-2015 (R202x), Machine-direction grammage variation measurement (gravimetric method) (reaffirmation of ANSI/TAPPI T 546 om-2015)

This procedure can be used to determine the short-term machine-direction variation in mass per unit area. These variations can be caused by defects in the stock approach system, headbox, or consistency control. This test method is not intended to identify the source of the variations, but rather to quantify them. The method has particular application to acceptance testing of both the papermaking process and the product. This test is laborious, but it is reliable and accurate. It requires cutting out samples, weighing samples, and data evaluation. The general procedures outlined in TAPPI T 410 "Grammage of Paper and Paperboard (Weight per Unit Area)" and in TAPPI T 402 "Standard Conditioning and Testing Atmospheres for Paper, Board, Pulp Handsheets, and Related Products," are used as basic references for this method. TAPPI T 545 "Cross-Machine Grammage Profile Measurement (Gravimetric Method)" is the counterpart to this method for the cross-machine evaluation.

Single copy price: Free

Obtain an electronic copy from: stnadards@tappi.org

Order from: standards@tappi.org

Send comments (copy psa@ansi.org) to: Natasha Bush-Postell, standards@tappi.org

Comment Deadline: March 14, 2022

TAPPI (Technical Association of the Pulp and Paper Industry)

15 Technology Parkway, Suite 115, Peachtree Corners, GA 30092 | standards@tappi.org, www.tappi.org

Reaffirmation

BSR/TAPPI T 550 om-2013 (R202x), Determination of equilibrium moisture in pulp, paper and paperboard for chemical analysis (reaffirmation of ANSI/TAPPI T 550 om-2013)

The following procedure applies to pulp, paper, paperboard, and paper products, except those containing significant quantities of materials other than water that are volatile at 105 ± 2 C, or less, or for materials that are oxidized or decomposed above 102 C. This method should be followed to calculate the results of a chemical analysis of pulp, paper, and paperboard on a moisture-free basis. This method should not be used to determine an “as received” or “use” moisture content.

Single copy price: Free

Obtain an electronic copy from: standards@tappi.org

Order from: standards@tappi.org

Send comments (copy psa@ansi.org) to: Natasha Bush-Postell, standards@tappi.org

TAPPI (Technical Association of the Pulp and Paper Industry)

15 Technology Parkway, Suite 115, Peachtree Corners, GA 30092 | standards@tappi.org, www.tappi.org

Reaffirmation

BSR/TAPPI T 1016 om-2010 (R202x), Average fiber diameter of fiber glass mats (reaffirmation of ANSI/TAPPI T 1016 om-2010)

This method covers the determination of the average fiber diameter (or distribution of diameters) of fibers used in nonwoven fiber glass mats.

Single copy price: Free

Obtain an electronic copy from: standards@tappi.org

Order from: standards@tappi.org

Send comments (copy psa@ansi.org) to: Natasha Bush-Postell, standards@tappi.org

TAPPI (Technical Association of the Pulp and Paper Industry)

15 Technology Parkway, Suite 115, Peachtree Corners, GA 30092 | standards@tappi.org, www.tappi.org

Revision

BSR/TAPPI T 489 om-202x, Bending resistance (stiffness) of paper and paperboard (Taber-type tester in basic configuration) (revision of ANSI/TAPPI T 489 om-2015)

This test method covers a procedure used to measure the resistance to bending of paper and paperboard and to determine the bending moment required to deflect the free end of a 38 mm (1.5 in)-wide vertically clamped specimen 15° from its centerline when the load is applied 50 mm (1.97 in) away from the clamp.

Single copy price: Free

Obtain an electronic copy from: standards@tappi.org

Order from: standards@tappi.org

Send comments (copy psa@ansi.org) to: Natasha Bush-Postell, standards@tappi.org

Comment Deadline: March 14, 2022

TAPPI (Technical Association of the Pulp and Paper Industry)

15 Technology Parkway, Suite 115, Peachtree Corners, GA 30092 | standards@tappi.org, www.tappi.org

Revision

BSR/TAPPI T 494 om-202x, Tensile properties of paper and paperboard (using constant rate of elongation apparatus) (revision of ANSI/TAPPI T 494 om-2013)

This test method describes the procedure, using constant-rate-of-elongation equipment, for determining four tensile breaking properties of paper and paperboard: tensile strength, stretch, tensile energy absorption, and tensile stiffness.

Single copy price: Free

Obtain an electronic copy from: standards@tappi.org

Order from: standards@tappi.org

Send comments (copy psa@ansi.org) to: Natasha Bush-Postell, standards@tappi.org

TAPPI (Technical Association of the Pulp and Paper Industry)

15 Technology Parkway, Suite 115, Peachtree Corners, GA 30092 | standards@tappi.org, www.tappi.org

Revision

BSR/TAPPI T 555 om-202x, Roughness of paper and paperboard (Print-surf method) (revision of ANSI/TAPPI T 555 om-2015)

This method measures the roughness of paper and paperboard under conditions intended to simulate the nip pressures and backing substrates found in printing processes. It is applicable to coated and uncoated papers and paperboards which are intended to be printed by contacting printing processes.

Single copy price: Free

Obtain an electronic copy from: standards@tappi.org

Order from: standards@tappi.org

Send comments (copy psa@ansi.org) to: Natasha Bush-Postell, standards@tappi.org

TAPPI (Technical Association of the Pulp and Paper Industry)

15 Technology Parkway, Suite 115, Peachtree Corners, GA 30092 | standards@tappi.org, www.tappi.org

Revision

BSR/TAPPI T 569 om-202x, Internal bond strength (Scott type) (revision of ANSI/TAPPI T 569 om-2014)

Printing, converting, and many product applications subject paper and paperboard to impulses, impacts, and shock loads into or out of the plane of the sheet. These can cause structural failures such as surface picks, blistering, or delaminations within the interior of the sheet. The common denominators of these failures are (a) the high velocity of the impact loads, (b) the short time period during which the material is stressed, frequently one to a few hundred milliseconds, and (c) the planar nature of the resultant sheet failure. Test results from this method may correlate with product failures of this type.

Single copy price: Free

Obtain an electronic copy from: standards@tappi.org

Order from: standards@tappi.org

Send comments (copy psa@ansi.org) to: Natasha Bush-Postell, standards@tappi.org

Comment Deadline: March 14, 2022

TAPPI (Technical Association of the Pulp and Paper Industry)

15 Technology Parkway, Suite 115, Peachtree Corners, GA 30092 | standards@tappi.org, www.tappi.org

Revision

BSR/TAPPI T 648 om-202x, Viscosity of coating clay slurry (revision of ANSI/TAPPI T 648 om-2014)

This method describes a procedure for the determination of the low- and high-shear viscosity of coating clays.

This is accomplished by the preparation of a completely dispersed 70% solids aqueous clay suspension with incremental introduction of dispersant to obtain the optimum dosage (minimum viscosity) for the low- and high-shearing rates.

Single copy price: Free

Obtain an electronic copy from: standards@tappi.org

Order from: standards@tappi.org

Send comments (copy psa@ansi.org) to: Natasha Bush-Postell, standards@tappi.org

TAPPI (Technical Association of the Pulp and Paper Industry)

15 Technology Parkway, Suite 115, Peachtree Corners, GA 30092 | standards@tappi.org, www.tappi.org

Revision

BSR/TAPPI T 835 om-202x, Water absorption of corrugating medium: water drop absorption test (revision of ANSI/TAPPI T 835 om-2014)

The water absorptivity of corrugating medium is measured by dropping a drop of water on the surface of a specimen and determining the time in seconds for the drop to be completely absorbed as evidenced by the loss of sheen. This method is applicable to corrugating medium as it is commercially produced by all processes. It is generally applicable to relatively unsized (water-leaf) containerboards. It may not be applicable to more highly sized boards or to grades produced in different grammage (basis weight) than those normally used in corrugating medium. The precision and repeatability of test results are dependent on the grade and manufacturing process.

Use caution when making comparisons between samples that differ significantly in basis weights or manufacturing process.

Single copy price: Free

Obtain an electronic copy from: standards@tappi.org

Order from: standards@tappi.org

Send comments (copy psa@ansi.org) to: Natasha Bush-Postell, standards@tappi.org

UL (Underwriters Laboratories)

47173 Benicia Street, Fremont, CA 94538 | Derrick.L.Martin@ul.org, <https://ul.org/>

Revision

BSR/UL 746A-202x, Standard for Safety for Polymeric Materials - Short Term Property Evaluations (revision of ANSI/UL 746A-2021)

The intent of this proposal is to align limits of replacement and the [addition/deletion] of additives in Table 9.1.

Single copy price: Free

Obtain an electronic copy from: <https://csds.ul.com/Home/ProposalsDefault.aspx>

Order from: <http://www.shopulstandards.com>

Send comments (copy psa@ansi.org) to: Follow the instructions in the following website to enter comments into the CSDS Work Area: <https://csds.ul.com/Home/ProposalsDefault.aspx>

Comment Deadline: March 14, 2022

UL (Underwriters Laboratories)

47173 Benicia Street, Fremont, CA 94538 | Derrick.L.Martin@ul.org, <https://ul.org/>

Revision

BSR/UL 746C-202x, Standard for Safety for Polymeric Materials - Use in Electrical Equipment Evaluations (revision of ANSI/UL 746C-2021)

This project covers the clarification on the use of the Gardner Impact Test and End-Product Ball-Impact for UV Light Exposure evaluation in UL 746C.

Single copy price: Free

Obtain an electronic copy from: <https://csds.ul.com/Home/ProposalsDefault.aspx>

Order from: <http://www.shopulstandards.com>

Send comments (copy psa@ansi.org) to: Follow the instructions in the following website to enter comments into the CSDS Work Area: <https://csds.ul.com/Home/ProposalsDefault.aspx>

Comment Deadline: March 29, 2022

ANS (American Nuclear Society)

555 North Kensington Avenue, La Grange Park, IL 60526 | kmurdoch@ans.org, www.ans.org

Revision

BSR/ANS 8.7-202x, Nuclear Criticality Safety in the Storage of Fissile Materials (revision of ANSI/ANS 8.7-1998 (R2017))

This standard is applicable to the storage of fissile materials. Mass and spacing limits are tabulated for uranium containing greater than 30 wt % ²³⁵U, and for plutonium as metals and oxides. Criteria for the range of application of these limits are provided.

Single copy price: \$96.00

Obtain an electronic copy from: orders@ans.org

Order from: orders@ans.org

Send comments (copy psa@ansi.org) to: pschroeder@ans.org

ASME (American Society of Mechanical Engineers)

Two Park Avenue, M/S 6-2B, New York, NY 10016-5990 | ansibox@asme.org, www.asme.org

Revision

BSR/ASME HST-3-202x, Performance Standard for Lever Hoists (revision of ANSI/ASME HST-3-2017)

This Standard establishes performance requirements for chain, wire-rope, and web-strap lever hoists for lifting, pulling, and tensioning applications. The specifications and information in this Standard apply to lever hoists of the following types: (1) ratchet-and-pawl operation with (a) roller-type load chain lifting medium, (b) welded-link-type load-chain lifting medium, (c) web-strap-type lifting medium, and (d) wire-rope-type lifting medium; (2) friction-brake operation with (a) roller-type load chain, (b) welded-link-type load chain, (c) web-strap-type lifting medium, and (d) wire-rope-type lifting medium. The requirements of this Standard shall be applied together with the requirements of ASME B30.21. Refer to ASME B30.21 for requirements pertaining to marking, construction, installation, inspection, testing, maintenance, and operation.

Single copy price: Free

Order from: <https://cstools.asme.org/csconnect/PublicReviewPage.cfm>

Send comments (copy psa@ansi.org) to: Justin Cassamassino; cassamassinoj@asme.org

Comment Deadline: March 29, 2022

TNI (The NELAC Institute)

PO Box 2439, Weatherford, TX 76086 | robert.wyeth@nelac-institute.org, www.NELAC-Institute.org

Revision

BSR/TNI EL-V1M6-Rev. 3.0-202x, Management and Technical Requirements for Laboratories Performing Environmental Analysis; Module 6: Quality Systems for Radiochemical Testing (revision and partition of ANSI/TNI EL-V1-2016)

This standard establishes detailed quality assurance and quality control requirements for environmental radiochemical laboratories. This module, in conjunction with the quality system specified in the general requirements module of Volume 1 of the TNI standard form the basis for the evaluation of environmental radiochemical laboratories. This Module is in need of updating, requiring consideration of items presented by stakeholders, and clarification of issues identified by the consensus body.

Single copy price: \$No charge

Obtain an electronic copy from: robert.wyeth@nelac-institute.org

Order from: Robert Wyeth; robert.wyeth@nelac-institute.org

Send comments (copy psa@ansi.org) to: Same

Project Withdrawn

In accordance with clause 4.2.1.3.3 Discontinuance of a standards project of the ANSI Essential Requirements, an accredited standards developer may abandon the processing of a proposed new or revised American National Standard or portion thereof if it has followed its accredited procedures. The following projects have been withdrawn accordingly:

ASME (American Society of Mechanical Engineers)

Two Park Avenue, 6th Floor, New York, NY 10016-5990 | ansibox@asme.org, www.asme.org

BSR/ASME B18.2.4.3M-1979 (S202x), Metric Slotted Hex Nuts (stabilized maintenance of ANSI/ASME B18.2.4.3M-1979 (R2017))

Inquiries may be directed to Maria Acevedo; ansibox@asme.org

Withdrawal of an ANS by ANSI-Accredited Standards Developer

In accordance with clause 4.2.1.3.2 Withdrawal by ANSI-Accredited Standards Developer of the ANSI Essential Requirements, the following American National Standards have been withdrawn as an ANS.

ASME (American Society of Mechanical Engineers)

Two Park Avenue, 6th Floor, New York, NY 10016-5990 | ansibox@asme.org, www.asme.org

ANSI/ASME B18.2.4.3M-1979 (R2017), Metric Slotted Hex Nuts

Questions may be directed to: Maria Acevedo; ansibox@asme.org

Final Actions on American National Standards

The standards actions listed below have been approved by the ANSI Board of Standards Review (BSR) or by an ANSI-Audited Designator, as applicable.

AGMA (American Gear Manufacturers Association)

1001 N Fairfax Street, 5th Floor, Alexandria, VA 22314-1587 | tech@agma.org, www.agma.org

Withdrawal

ANSI/AGMA ISO 6336-6-A-2008 (R2014), Calculation of Load Capacity of Spur and Helical Gears - Part 6: Calculation of Service Life Under Variable Load (withdrawal of ANSI/AGMA ISO 6336-6-A-2008 (R2014)) Final Action Date: 1/18/2022

APCO (Association of Public-Safety Communications Officials-International)

351 N. Williamson Boulevard, Daytona Beach, FL 32114-1112 | apcostandards@apcointl.org, www.apcointl.org

Revision

ANSI/APCO 3.107.2-2022, Core Competencies and Minimum Training Requirements for Public Safety Communications Technician (revision and redesignation of ANSI/APCO 3.107.1-2015) Final Action Date: 1/18/2022

Revision

ANSI/APCO 3.109.3-2022, Core Competencies and Minimum Training Standards for Public Safety Communications Manager/Director (revision and redesignation of ANSI/APCO 3.109.2-2014) Final Action Date: 1/18/2022

ASABE (American Society of Agricultural and Biological Engineers)

2950 Niles Road, Saint Joseph, MI 49085 | vangilder@asabe.org, https://www.asabe.org/

National Adoption

ANSI/ASAE S390.7 (ISO 12934-2022) MONYEAR, Tractors and machinery for agriculture and forestry - Basic types - Vocabulary (identical national adoption of ISO 12934:2021 and revision of ANSI/ASAE S390.6 (ISO 12934:2013)-DEC16) Final Action Date: 1/18/2022

ASHRAE (American Society of Heating, Refrigerating and Air-Conditioning Engineers, Inc.)

180 Technology Parkway, Peachtree Corners, GA 30092 | mweber@ashrae.org, www.ashrae.org

Addenda

ANSI/ASHRAE Addendum 62.1aa-2019, Ventilation for Acceptable Indoor Air Quality (addenda to ANSI/ASHRAE Standard 62.1-2019) Final Action Date: 1/21/2022

Addenda

ANSI/ASHRAE Addendum a to Standard 217-2020, Non-Emergency Ventilation in Enclosed Road, Rail, and Mass Transit Facilities (addenda to ANSI/ASHRAE Standard 217-2020) Final Action Date: 1/21/2022

Addenda

ANSI/ASHRAE Addendum bv to ANSI/ASHRAE Standard 135-2020, BACnet - A Data Communication Protocol for Building Automation and Control Networks (addenda to ANSI/ASHRAE Standard 135-2020) Final Action Date: 1/21/2022

Addenda

ANSI/ASHRAE Addendum ca to ANSI/ASHRAE Standard 135-2020, BACnet - A Data Communication Protocol for Building Automation and Control Networks (addenda to ANSI/ASHRAE Standard 135-2016) Final Action Date: 1/21/2022

ASHRAE (American Society of Heating, Refrigerating and Air-Conditioning Engineers, Inc.)

180 Technology Parkway, Peachtree Corners, GA 30092 | cking@ashrae.org, www.ashrae.org

Addenda

ANSI/ASHRAE Addendum cc to ANSI/ASHRAE Standard 135-2020, BACnet - A Data Communication Protocol for Building Automation and Control Networks (addenda to ANSI/ASHRAE Standard 135-2016) Final Action Date: 1/21/2022

Addenda

ANSI/ASHRAE Addendum ce to ANSI/ASHRAE Standard 135-2020, BACnet - A Data Communication Protocol for Building Automation and Control Networks (addenda to ANSI/ASHRAE Standard 135-2016) Final Action Date: 1/21/2022

Addenda

ANSI/ASHRAE Addendum c to ANSI/ASHRAE Standard 52.2-2017, Method of Testing General Ventilation Air Cleaning Devices for Removal Efficiency by Particle Size (addenda to ANSI/ASHRAE Standard 52.2-2017) Final Action Date: 1/21/2022

Addenda

ANSI/ASHRAE/ICC/IES/USGBC Addendum h to ANSI/ASHRAE/ICC/IES/USGBC Standard 189.1-2020, Standard for the Design of High-Performance Green Buildings Except Low-Rise Residential Buildings (addenda to ANSI/ASHRAE/ICC/IES/USGBC Standard 189.1-2020) Final Action Date: 1/21/2022

Addenda

ANSI/ASHRAE/IES Addendum au to ANSI/ASHRAE/IES Standard 90.1-2019, Energy Standard for Buildings Except Low-Rise Residential Buildings (addenda to ANSI/ASHRAE/IES Standard 90.1-2019) Final Action Date: 1/21/2022

Addenda

ANSI/ASHRAE/IES Addendum aw to ANSI/ASHRAE/IES Standard 90.1-2019, Energy Standard for Buildings Except Low-Rise Residential Buildings (addenda to ANSI/ASHRAE/IES Standard 90.1-2019) Final Action Date: 1/21/2022

Addenda

ANSI/ASHRAE/IES Addendum az to ANSI/ASHRAE/IES Standard 90.1-2019, Energy Standard for Buildings Except Low-Rise Residential Buildings (addenda to ANSI/ASHRAE/IES Standard 90.1-2019) Final Action Date: 1/21/2022

Addenda

ANSI/ASHRAE/IES Addendum be to ANSI/ASHRAE/IES Standard 90.1-2019, Energy Standard for Buildings Except Low-Rise Residential Buildings (addenda to ANSI/ASHRAE/IES Standard 90.1-2019) Final Action Date: 1/21/2022

Addenda

ANSI/ASHRAE/IES Addendum bh to ANSI/ASHRAE/IES Standard 90.1-2019, Energy Standard for Buildings Except Low-Rise Residential Buildings (addenda to ANSI/ASHRAE/IES Standard 90.1-2019) Final Action Date: 1/21/2022

Addenda

ANSI/ASHRAE/IES Addendum bk to ANSI/ASHRAE/IES Standard 90.1-2019, Energy Standard for Buildings Except Low-Rise Residential Buildings (addenda to ANSI/ASHRAE/IES Standard 90.1-2019) Final Action Date: 1/21/2022

Addenda

ANSI/ASHRAE/IES Addendum bm to ANSI/ASHRAE/IES Standard 90.1-2019, Energy Standard for Buildings Except Low-Rise Residential Buildings (addenda to ANSI/ASHRAE/IES Standard 90.1-2019) Final Action Date: 1/21/2022

New Standard

ANSI/ASHRAE Standard 23-2022, Methods for Performance Testing Positive Displacement Refrigerant Compressors and Compressor Units (new standard) Final Action Date: 1/21/2022

ASHRAE (American Society of Heating, Refrigerating and Air-Conditioning Engineers, Inc.)

180 Technology Parkway, Peachtree Corners, GA 30092 | cking@ashrae.org, www.ashrae.org

Revision

ANSI/ASHRAE Standard 41.3-2022, Standard Methods for Pressure Measurement (revision of ANSI/ASHRAE Standard 41.3-2014) Final Action Date: 1/21/2022

ASME (American Society of Mechanical Engineers)

Two Park Avenue, 6th Floor, New York, NY 10016-5990 | ansibox@asme.org, www.asme.org

Reaffirmation

ANSI/ASME B5.62M-2016 (R2022), Hollow Taper Tooling with Flange-Face Contact (reaffirmation and redesignation of ANSI/ASME B5.62-2016) Final Action Date: 1/21/2022

Revision

ANSI/ASME B18.2.2-2022, Nuts for General Applications: Machine Screw Nuts, Hex, Square, Hex Flange, and Coupling Nuts (Inch Series) (revision of ANSI/ASME B18.2.2-2015) Final Action Date: 1/21/2022

ASTM (ASTM International)

100 Barr Harbor Drive, West Conshohocken, PA 19428-2959 | accreditation@astm.org, www.astm.org

Revision

ANSI/ASTM E1590-2022, Test Method for Fire Testing of Mattresses (revision of ANSI/ASTM E1590-2017) Final Action Date: 1/15/2022

Revision

ANSI/ASTM F1878-2021, Guide for Escort Vessel Evaluation and Selection (revision of ANSI/ASTM F1878-2009 (R2015)) Final Action Date: 12/20/2021

Revision

ANSI/ASTM F2510-2022, Specification for Resilient Connectors between Reinforced Concrete Manhole Structures and Corrugated Dual- and Triple-Wall Polyethylene and Polypropylene Pipes (revision of ANSI/ASTM F2510/F2510M -2017a) Final Action Date: 1/15/2022

HL7 (Health Level Seven)

3300 Washtenaw Avenue, Suite 227, Ann Arbor, MI 48104 | Karenvan@HL7.org, www.hl7.org

Reaffirmation

ANSI/HL7 V3 CTS, R2-2015 (R2022), HL7 Version 3 Standard: Common Terminology Services, Release 2 (reaffirmation of ANSI/HL7 V3 CTS, R2-2015) Final Action Date: 1/18/2022

NSF (NSF International)

789 N. Dixboro Road, Ann Arbor, MI 48105-9723 | arose@nsf.org, www.nsf.org

Revision

ANSI/NSF 18-2022 (i20r1), Manual Food and Beverage Dispensing Equipment (revision of ANSI/NSF 18-2020) Final Action Date: 1/17/2022

SCTE (Society of Cable Telecommunications Engineers)

140 Philips Rd, Exton, PA 19341 | kcooney@scte.org, www.scte.org

Reaffirmation

ANSI/SCTE 10-2014 (R2021), Test Method for Flexible Coaxial Cable Impact (reaffirmation of ANSI/SCTE 10-2014) Final Action Date: 1/18/2022

SCTE (Society of Cable Telecommunications Engineers)

140 Philips Rd, Exton, PA 19341 | kcooney@scte.org, www.scte.org

Reaffirmation

ANSI/SCTE 32-2016 (R2021), Ampacity of Coaxial Telecommunications Cables (reaffirmation of ANSI/SCTE 32-2016)
Final Action Date: 1/18/2022

Reaffirmation

ANSI/SCTE 34-2016 (R2021), Test Method for Cored Depth Verification (reaffirmation of ANSI/SCTE 34-2016) Final
Action Date: 1/18/2022

Reaffirmation

ANSI/SCTE 39-2013 (R2021), Test Method for Static Minimum Bending Radius for Coaxial Trunk, Feeder, and
Distribution Cables (reaffirmation of ANSI/SCTE 39-2013) Final Action Date: 1/18/2022

Reaffirmation

ANSI/SCTE 49-2011 (R2021), Test Method for Velocity of Propagation (reaffirmation of ANSI/SCTE 49-2011) Final
Action Date: 1/18/2022

Reaffirmation

ANSI/SCTE 60-2015 (R2021), Test Method for Interface Moisture Migration Double Ended (reaffirmation of ANSI/SCTE
60-2015) Final Action Date: 1/18/2022

Reaffirmation

ANSI/SCTE 88-2012 (R2021), Test Methods for Polyethylene Jacket Longitudinal Shrinkage (reaffirmation of ANSI/SCTE
88-2012) Final Action Date: 1/18/2022

Reaffirmation

ANSI/SCTE 173-2-2017 (R2021), Framework for Implementing Preferential Telecommunications in IPCablecom and
IPCablecom2 Networks (reaffirmation of ANSI/SCTE 173-2-2017) Final Action Date: 1/18/2022

Reaffirmation

ANSI/SCTE 173-3-2017 (R2021), Specification for Authentication in Preferential Telecommunications over IPCablecom2
Networks (reaffirmation of ANSI/SCTE 173-3-2017) Final Action Date: 1/18/2022

Reaffirmation

ANSI/SCTE 173-4-2017 (R2021), Specification for Priority in Preferential Telecommunications over IPCablecom2
Networks (reaffirmation of ANSI/SCTE 173-4-2017) Final Action Date: 1/18/2022

Revision

ANSI/SCTE 30-2021, Digital Program Insertion Splicing API (revision of ANSI/SCTE 30-2017) Final Action Date:
1/18/2022

Revision

ANSI/SCTE 93-2020, Test Method for Connector/Cable Twist (revision of ANSI/SCTE 93-2013) Final Action Date:
1/18/2022

Revision

ANSI/SCTE 230-2021, Recommended Practice for Proper Handling of Audio-Video Synchronization in Cable Systems
(revision of ANSI/SCTE 230-2016) Final Action Date: 1/18/2022

UL (Underwriters Laboratories)

12 Laboratory Drive, Research Triangle Park, NC 27709-3995 | Nicolette.A.Weeks@ul.org, <https://ul.org/>

National Adoption

ANSI/UL 12402-9-2022, Standard for Personal Flotation Devices - Part 9: Test Methods (October 8, 2021) (national adoption of ISO 12402-9 with modifications and revision of ANSI/UL 12402-9-2021) Final Action Date: 1/18/2022

Revision

ANSI/UL 758-2022, Standard for Appliance Wiring Material (November 5, 2021) (revision of ANSI/UL 758-2021) Final Action Date: 1/20/2022

Revision

ANSI/UL 1238-2022, Standard for Safety for Control Equipment for Use with Flammable Liquid and LP-Gas Dispensing Devices (revision of ANSI/UL 1238-2019) Final Action Date: 1/19/2022

Revision

ANSI/UL 2775-2022, Standard for Fixed Condensed Aerosol Extinguishing System Units (October 15, 2021) (revision of ANSI/UL 2775-2021) Final Action Date: 1/21/2022

VITA (VMEbus International Trade Association (VITA))

929 W. Portobello Avenue, Mesa, AZ 85210 | jing.kwok@vita.com, www.vita.com

Revision

ANSI/VITA 46.11-2022, System Management on VPX Standard (revision of ANSI/VITA 46.11-2015) Final Action Date: 1/18/2022

Call for Members (ANS Consensus Bodies)

Directly and materially interested parties who wish to participate as a member of an ANS consensus body for the standards listed are requested to contact the sponsoring developer directly in a timely manner.

AAMI (Association for the Advancement of Medical Instrumentation)

901 N. Glebe Road, Suite 300, Arlington, VA 22203 | abenedict@aami.org, www.aami.org

BSR/AAMI/ISO 17664-1-202x, Processing of health care products - Information to be provided by the medical device manufacturer for the processing of medical devices - Part 1: Critical and semi-critical medical devices (identical national adoption of ISO 17664-1:2021 and revision of ANSI/AAMI/ISO 17664-2017)

BSR/AAMI/ISO 17664-2-202x, Processing of health care products - Information to be provided by the medical device manufacturer for the processing of medical devices - Part 2: Non-critical medical devices (identical national adoption of ISO 17664-2:2021)

ACP (American Clean Power Association)

1501 M Street NW, Suite 900, Washington, DC 20005 | standards@cleanpower.org, www.cleanpower.org

BSR/ACP 1000-2.1-202x, Definitions and Nomenclatures (new standard)

BSR/ACP 1000-2.2-202x, Rescue Training Requirements (new standard)

BSR/ACP 1000-2.3-202x, Fall Protection Training Requirements (new standard)

AMCA (Air Movement and Control Association)

30 West University Drive, Arlington Heights, IL 60004-1893 | shrutik@amca.org, www.amca.org

BSR/AMCA 280-202x, Method of Test for Wind Loading of Fans (new standard)

ASME (American Society of Mechanical Engineers)

Two Park Avenue, M/S 6-2B, New York, NY 10016-5990 | ansibox@asme.org, www.asme.org

BSR/ASME HST-3-202x, Performance Standard for Lever Hoists (revision of ANSI/ASME HST-3-2017)

NECA (National Electrical Contractors Association)

1201 Pennsylvania Avenue, Suite 1200, Washington, DC 20004 | Aga.golriz@necanet.org, www.neca-neis.org

BSR/NECA 5-202X, Recommended Practice for Prefabrication of Electrical Installations for Construction (new standard)

NSF (NSF International)

789 N. Dixboro Road, Ann Arbor, MI 48105-9723 | arose@nsf.org, www.nsf.org

BSR/NSF 18-202x (i21r1), Manual Food and Beverage Dispensing Equipment (revision of ANSI/NSF 18-2020)

BSR/NSF 49-202x (i161r1), Biosafety Cabinetry: Design, Construction, Performance, and Field Certification (revision of ANSI/NSF 49-2020)

BSR/NSF/CAN 50-202x (i140r5), Equipment and Chemicals for Swimming Pools, Spas, Hot Tubs and Other Recreational Water Facilities (revision of ANSI/NSF/CAN 50-2020)

BSR/NSF/CAN 372-202x (i6r1), Drinking Water System Components - Lead Content (revision of ANSI/NSF/CAN 372-2020)

Call for Members (ANS Consensus Bodies)

ANSI Accredited Standards Developer

INCITS Executive Board – ANSI Accredited SDO and US TAG to ISO/IEC JTC 1, Information Technology

The InterNational Committee for Information Technology Standards (INCITS), an ANSI accredited SDO, is the forum of choice for information technology developers, producers and users for the creation and maintenance of formal de jure IT standards. INCITS' mission is to promote the effective use of Information and Communication Technology through standardization in a way that balances the interests of all stakeholders and increases the global competitiveness of the member organizations.

The INCITS Executive Board serves as the consensus body with oversight of its 40+ Technical Committees. Additionally, the INCITS Executive Board has the international leadership role as the US Technical Advisory Group (TAG) to ISO/IEC JTC 1, Information Technology.

Membership in the INCITS Executive Board is open to all directly and materially affected parties in accordance with INCITS membership rules. To find out more about participating on the INCITS Executive Board, contact Jennifer Garner at jgarner@itic.org or visit <http://www.incits.org/participation/membership-info> for more information.

Membership in all interest categories is always welcome; however, the INCITS Executive Board seeks to broaden its membership base in the following categories:

- Service Providers
- Users
- Standards Development Organizations and Consortia
- Academic Institutions

Call for Members (ANS Consensus Bodies)

ANSI Accredited Standards Developer

NCPDP - National Council for Prescription Drug Programs

Enrollment in the 2022 Consensus Group opens January 10, 2022 and closes February 11, 2022.

National Council for Prescription Drug Programs (NCPDP) Enrollment in the 2022 Consensus Group opens **Monday, January 10, 2022** and closes at **8:00 p.m. EST on Friday, February 11, 2022**. Information concerning the Consensus Group registration process is available by contacting: Margaret Weiker, (480) 477-1000, mweiker@ncpdp.org

Standards:

- Audit Transaction Standard – supports an electronic audit transaction that facilitates requests, responses, and final outcomes transmissions for both “Desk Top” claim audits and for in-store audit notices.
- Batch Standard Subrogation - provides a uniform approach to efficiently process post-payment subrogation claims and eliminate the numerous custom formats used in the industry today.
- Benefit Integration Standard - supports the communication of accumulator data (such as deductible and out of pocket) between Benefit Partners to administer integrated benefits for a member.
- Billing Unit Standard - provides a consistent and well-defined billing unit for use in pharmacy transactions. This results in time savings and accuracy in billing and reimbursement.
- Financial Information Reporting Standard – provides a process whereby financial information is moved from one PBM to another when a patient changes benefit plans.
- Formulary and Benefit Standard – provides a standard means for pharmacy benefit payers (including health plans and Pharmacy Benefit Managers) to communicate formulary and benefit information to prescribers via technology vendor systems.
- Manufacturer Rebate Standard – provides a standardized format for the electronic submission of rebate information from Pharmacy Management Organizations (PMOs) to Pharmaceutical Industry Contracting Organizations (PICOs).
- Medicaid Subrogation Standard – provides guidelines for the process whereby a Medicaid agency can communicate to a processor for reimbursement. The state has reimbursed the pharmacy provider for covered services and now is pursuing reimbursement from other payers for these services.
- Medical Rebates Data Submission Standard – provides a standardized format for health plans’ rebate submissions to multiple manufacturers throughout the industry. Implementation of the medical also eliminates the need for manufacturers to create internal mapping processes to standardize unique data formats from each health plan or third party administrator.
- Post Adjudication Standard – provides a format for supplying detailed drug or utilization claim information after the claim has been adjudicated.
- Prescription Drug Monitoring Programs (PDMP) Reporting Standard – developed to report controlled substance and other required drug information to assist healthcare providers to deter prescription drug abuse to ensure access for patients with valid medical needs.
- Prescription Transfer Standard – developed to create file formats for the purpose of electronically transferring prescriptions between pharmacies.
- Prior Authorization Transfer Standard – developed to define the file format and correct usage for electronically transferring existing prior authorization data between payer/processors when transitioning clients, performing system database or platform changes, or other scenarios where an existing prior authorization record is stored in one location and needs to be moved to another.

Call for Members (ANS Consensus Bodies)

ANSI Accredited Standards Developer

NCPDP - National Council for Prescription Drug Programs

Enrollment in the 2022 Consensus Group opens January 10, 2022 and closes February 11, 2022.

(Continued from previous page)

- Product Identifiers Standard – developed to provide a standard for consistent formatting and utilization of product identifiers in healthcare and to provide clarification for maintenance of these specific product identifiers.
- Real-Time Prescription Benefit Standard – developed a real-time pharmacy benefit inquiry from a provider EMR application to: leverage pharmacy industry standards and technology infrastructure, to deliver an accurate, pharmacy specific, “Patient Pay Amount” for a proposed medication and quantity and to collaboratively align stakeholders.
- Retiree Drug Subsidy Standard – developed to assist in the automation of summarized drug cost and related data transfer from one processor/pharmacy benefit manager to another processor/ pharmacy benefit manager for continuation of the CMS Retiree Drug Subsidy (RDS) cost data reporting by the receiving entity.
- SCRIPT Standard – developed for transmitting prescription information electronically between prescribers, providers, and other entities.
- Specialized Standard – developed for transmitting information electronically between prescribers, providers, and other entities. The standard addresses the electronic transmission of census information about a patient between a facility and a pharmacy, medication therapy management transactions between providers, payers, pharmacies, and other entities. It will include other transactions for electronic exchanges between these entities in the future.
- Specialty Pharmacy Data Reporting Standard - provides a standardized format for the data submitted by specialty pharmacy to drug manufacturers/others to support programs and agreements between the parties.
- State Medicaid Provider File Standard - developed a standard by which state Medicaid agencies or other entities could communicate their provider data with the MCOs/PBMs in a consistent and streamlined manner.
- Telecommunication Standard – developed a standardized format for electronic communication of claims and other transactions between pharmacy providers, insurance carriers, third-party administrators, and other responsible parties.
- Uniform Healthcare Payer Data Standard – developed a standard format for pharmacy claim data to support the reporting requirements of claim data to states or their designees.

ANSI Accredited Standards Developer

SCTE (Society of Cable Telecommunications Engineers)

SCTE, an ANSI-accredited SDO, is the primary organization for the creation and maintenance of standards for the cable telecommunications industry. SCTE’s standards mission is to develop standards that meet the needs of cable system operators, content providers, network and customer premises equipment manufacturers, and all others who have an interest in the industry through a fair, balanced and transparent process.

SCTE is currently seeking to broaden the membership base of its ANS consensus bodies and is interested in new members in all membership categories to participate in new work in fiber-optic networks, advanced advertising, 3D television, and other important topics. Of particular interest is membership from the content (program and advertising) provider and user communities. Membership in the SCTE Standards Program is open to all directly and materially affected parties as defined in SCTE’s membership rules and operating procedures. More information is available at www.scte.org or by e-mail from standards@scte.org.

Membership in the SCTE Standards Program is open to all directly and materially affected parties as defined in SCTE’s membership rules and operating procedures. More information is available at www.scte.org or by e-mail from standards@scte.org.

Call for Comment of ANS Limited Substantive Changes

ANSI Accredited Standards Developers

IAPMO (ASSE Chapter) - ASSE International Chapter of IAPMO

ANSI/ASSE Series 6000-2021 - 30-Day Comment Deadline By February 28, 2022

This Call for Comment of Limited Substantive Changes to the Approved American National Standard is available for review & comment until **February 28, 2022**

ANSI/ASSE Series 6000-2021

Professional Qualifications Standard for Medical Gas Systems Personnel

(revision of ANSI/ASSE Series 6000-2018)

Update to Standard 35-2.3.1 a

The Bulk Medical Gas/Cryogenic Fluid Central Supply Systems Verifier shall be able to identify and describe the proper installation requirements for bulk medical gas /cryogenic fluid central supply system pertaining to:

Remove: a) The firms standing operating procedures (SOPs)

Order from: Marianne Waickman; marianne.waickman@asse-plumbing.org

Send comments (with optional copy to psa@ansi.org) to: Same

Obtain an electronic copy from: marianne.waickman@asse-plumbing.org

Single copy price: Free

[Click here to view these changes in full](#)

Marianne Waickman

Professional Qualifications Director

ASSE International Chapter of IAPMO (IAPMO (ASSE Chapter))

18927 Hickory Creek Drive, Suite 220

Mokena, IL 60448

p: (708) 995-3015

e: marianne.waickman@asse-plumbing.org

American National Standards (ANS) Announcements

Corrections

ASHRAE - American Society of Heating, Refrigerating and Air-Conditioning Engineers, Inc.

BSR/ASHRAE Standard 228-202x call for comment period

BSR/ASHRAE Standard 228-202x was announced for public review one week ahead of schedule in last week's Call for Comment section of Standards Action. The comment period will in fact begin with this edition, Jan-28, 2022, and will end Mar-14, 2022. Please direct inquiries to: Carmen King; cking@ashrae.org.

Corrections

IAPMO (ASSE Chapter) - ASSE International Chapter of IAPMO

BSR/ASSE Series 21000-202x proposal is a revision under IAPMO (ASSE Chapter)

The 12/3/2021, Standards Action PINS notice for BSR/ASSE Series 21000-202x had an incorrect project action and Developer Acronym. This notice should have been listed as follows:

IAPMO (ASSE Chapter)

ASSE International Chapter of IAPMO

BSR/ASSE Series 21000-202x

Professional Qualifications Standard for Rainwater Catchment Systems Personnel

(revision of ANSI/ASSE Series 21000-2017)

Please direct inquiries to: Marianne Waickman; marianne.waickman@asse-plumbing.org

Effective Date Extended

ASSP (Safety) - American Society of Safety Professionals

ANSI/ASSP Z359.14-2021 Effective Date Extended: February 1, 2023

The **Z359 Fall Protection and Fall Arrest Committee** has voted to extend the effective date for ANSI/ASSP Z359.14-2021 Safety Requirements for Self-Retracting Devices for Personal Fall Arrest and Rescue Systems. The date has been extended by six months due to the current state of global supply chains and shipping/freight delays, and delays in raw materials used in manufacturing and testing. The effective date for ANSI/ASSP Z359.14-2021 is now **February 1, 2023**. For any questions, please email LBauerschmidt@assp.org.

Accreditation Announcements (Standards Developers)

Approval of Reaccreditation – ASD

HPS (ASC N13) - Health Physics Society Radiation Protection

Effective January 25, 2022

The reaccreditation of **HPS (ASC N13 - Radiation Protection)** has been approved at the direction of ANSI's Executive Standards Council, under its recently revised operating procedures for documenting consensus on HPS (ASC N13)-sponsored American National Standards, effective **January 25, 2022**. For additional information, please contact: Amy Wride-Graney, Health Physics Society (HPS (ASC N13)) | 1313 Dolley Madison Blvd, Suite 402, McLean, VA 22101 | (703) 790-1745, awride-graney@burkinc.com

Approval of Reaccreditation – ASD

HPS (ASC N43) - Health Physics Society Equipment for Non-Medical Radiation Applications

Effective January 25, 2022

The reaccreditation of the **Health Physics Society (ASC N43 -Equipment for Non-Medical Radiation Applications)** has been approved at the direction of ANSI's Executive Standards Council, under its recently revised operating procedures for documenting consensus on HPS (ASC N43)-sponsored American National Standards, effective **January 25, 2022**. For additional information, please contact: Amy Wride-Graney, Health Physics Society (HPS (ASC N43)) | 1313 Dolley Madison Blvd, Suite 402, McLean, VA 22101 | (703) 790-1745, awride-graney@burkinc.com

Public Review of Application for ASD Accreditation

CFRE - CFRE International

Comment Deadline: February 28, 2022

CFRE International, a new ANSI member in 2022, has submitted an application for accreditation as an ANSI Accredited Standards Developer (ASD) and proposed operating procedures for documenting consensus on CFRE-sponsored American National Standards. CFRE International's proposed scope of standards activity is as follows:

Competency requirements for fundraising professionals

To obtain a copy of CFRE International's application and proposed operating procedures or to offer comments, please contact: Sara Duginske, CFRE International (CFRE) | 225 Reinekers Lane, Suite 625, Alexandria, VA 22314 | (703) 820-5555, sduginske@cfre.org. Please submit any comments to CFRE International by **February 28, 2022**, with a copy to the ExSC Recording Secretary in ANSI's New York Office (E-mail: Jthomps@ANSI.org). As the proposed procedures are available electronically, the public review period is 30 days.

[Click here to view or download a copy of CFRE International's proposed operating procedures from ANSI Online during the public review period at this URL.](#)

Meeting Notices (Standards Developers)

ANSI Accredited Standards Developer

A3 - Association for Advancing Automation

Meeting Times March & April 2022

ANSI-Accredited Standards Committee: R15.06, Industrial Robot Safety

Meeting Format & Location: Hybrid; In-person in Memphis, TN; Remote via GoToMeeting

Meeting Sponsor/Host: FedEx; The University of Memphis

Purpose: SAC Comment resolution for TR 906; Prepare for update of R15.06 (U.S. national adoption of ISO 10218-1,2, which is being updated)

Day/Date/Time: Monday, March 7, 2022; 8:30 AM – 4:45 PM (Central Time) / 6:30 AM – 2:45 PM (PT)

ANSI-Accredited Standards Committee: R15.08, Industrial Mobile Robot Safety

Meeting (1) Meeting Format & Location: Hybrid; In-person in Memphis, TN; Remote via GoToMeeting

Meeting Sponsor/Host: FedEx; The University of Memphis

Purpose: R15.08 Committee Internal Comment resolution for R15.08 Part 2

Day/Date/Time: Wednesday, March 9, 2022 9:30 AM (Central Time) – Thursday, March 10, 2022, 4:45 PM (CT)

Meeting (2) Meeting Format & Location: Remote via GoToMeeting

Meeting Sponsor/Host: A3, the Association for Advancing Automation

Purpose: Complete Committee Internal Comment resolution for R15.08 Part 2, if not completed at in-person (hybrid) meeting March 9 & 10, 2022; arrive at consensus that the R15.08 Part 2 is ready for balloting to the R15 SAC

Day/Date/Time: The meeting will be held in several sessions as follows:

Virtual Session #1: Tuesday, March 15, 2022; 10:00 AM – 12:00 noon (Eastern Time) / 7:00 AM – 9:00 AM (PT)

Virtual Session #2: Thursday, March 17, 2022; 10:00 AM – 12:00 noon (ET) / 7:00 AM – 9:00 AM (PT)

Virtual Session #3: Tuesday, March 22, 2022; 10:00 AM – 12:00 noon (ET) / 7:00 AM – 9:00 AM (PT)

Virtual Session #4: Thursday, March 24, 2022; 10:00 AM – 12:00 noon (ET) / 7:00 AM – 9:00 AM (PT)

Virtual Session #5: Tuesday, April 5, 2022; 10:00 AM – 12:00 noon (ET) / 7:00 AM – 9:00 AM (PT)

Virtual Session #6: Thursday, April 7, 2022; 10:00 AM – 12:00 noon (ET) / 7:00 AM – 9:00 AM (PT)

Note: Some or all of these meeting sessions could be cancelled if not needed.

ANSI-Accredited Standards Committee: R15 Standards Approval Committee (SAC) (consensus body)

Meeting Format & Location: Hybrid; In-person in Memphis, TN; Remote via GoToMeeting

Meeting Sponsor/Host: FedEx; The University of Memphis

Purpose: Discuss Administrative Procedures for R15 committees; discuss current or upcoming documents for ballot

Day/Date/Time: Friday, March 11, 2022; 8:30 AM – 11:30 AM (CT)

For More Information: Contact Carole Franklin, cfranklin@automate.org.

Meeting Notices (Standards Developers)

ANSI Accredited Standards Developer

ADA Organization - American Dental Association

Plenary meetings on February 23 and March 23, 2022

The **ADA Standards Committee on Dental Informatics (SCDI)** and the **ADA Standards Committee on Dental Products (SCDP)** will hold their next plenary meetings on **February 23 and March 23, 2022**, respectively. Additional meetings including of SCDI and SCDP Working Groups and the U.S. Technical Advisory Group (TAG) for the International Organization for Standardization's (ISO) Technical Committee on Dentistry will also be taking place in February and March. There is no charge for any of these meetings and they are open to all interested parties, however, registration is required to attend certain meetings. Meeting and registration information may be found at www.ada.org/dentalstandards.

American National Standards (ANS) Process

Please visit ANSI's website (www.ansi.org) for resources that will help you to understand, administer and participate in the American National Standards (ANS) process. Documents posted at these links are updated periodically as new documents and guidance are developed, whenever ANS-related procedures are revised, and routinely with respect to lists of proposed and approved ANS. The main ANS-related link is www.ansi.org/asd and here are some direct links as well as highlights of information that is available:

Where to find Procedures, Guidance, Interpretations and More...

Please visit ANSI's website (www.ansi.org)

- ANSI Essential Requirements: Due process requirements for American National Standards (always current edition): www.ansi.org/essentialrequirements
- ANSI Standards Action (weekly public review announcements of proposed ANS and standards developer accreditation applications, listing of recently approved ANS, and proposed revisions to ANS-related procedures): www.ansi.org/standardsaction
- Accreditation information – for potential developers of American National Standards (ANS): www.ansi.org/sdoaccreditation
- ANS Procedures, ExSC Interpretations and Guidance (including a slide deck on how to participate in the ANS process and the BSR-9 form): www.ansi.org/asd
- Lists of ANSI-Accredited Standards Developers (ASDs), Proposed ANS and Approved ANS: www.ansi.org/asd
- American National Standards Key Steps: www.ansi.org/anskeysteps
- American National Standards Value: www.ansi.org/ansvalue
- ANS Web Forms for ANSI-Accredited Standards Developers - PINS, BSR8|108, BSR11, Technical Report: <https://www.ansi.org/portal/psawebforms/>
- Information about standards Incorporated by Reference (IBR): <https://ibr.ansi.org/>
- ANSI - Education and Training: www.standardslearn.org

American National Standards Under Continuous Maintenance

The ANSI Essential Requirements: Due Process Requirements for American National Standards provides two options for the maintenance of American National Standards (ANS): periodic maintenance (see clause 4.7.1) and continuous maintenance (see clause 4.7.2). Continuous maintenance is defined as follows:

The standard shall be maintained by an accredited standards developer. A documented program for periodic publication of revisions shall be established by the standards developer. Processing of these revisions shall be in accordance with these procedures. The published standard shall include a clear statement of the intent to consider requests for change and information on the submittal of such requests. Procedures shall be established for timely, documented consensus action on each request for change and no portion of the standard shall be excluded from the revision process. In the event that no revisions are issued for a period of four years, action to reaffirm or withdraw the standard shall be taken in accordance with the procedures contained in the ANSI Essential Requirements.

The Executive Standards Council (ExSC) has determined that for standards maintained under the Continuous Maintenance option, separate PINS announcements are not required. The following ANSI Accredited Standards Developers have formally registered standards under the Continuous Maintenance option.

-
- AAMI (Association for the Advancement of Medical Instrumentation)
 - AARST (American Association of Radon Scientists and Technologists)
 - AGA (American Gas Association)
 - AGSC (Auto Glass Safety Council)
 - ASC X9 (Accredited Standards Committee X9, Incorporated)
 - ASHRAE (American Society of Heating, Refrigerating and Air-Conditioning Engineers, Inc.)
 - ASME (American Society of Mechanical Engineers)
 - ASTM (ASTM International)
 - GBI (Green Building Initiative)
 - HL7 (Health Level Seven)
 - Home Innovation (Home Innovation Research Labs)
 - IES (Illuminating Engineering Society)
 - ITI (InterNational Committee for Information Technology Standards)
 - MHI (Material Handling Industry)
 - NBBPVI (National Board of Boiler and Pressure Vessel Inspectors)
 - NCPDP (National Council for Prescription Drug Programs)
 - NEMA (National Electrical Manufacturers Association)
 - NISO (National Information Standards Organization)
 - NSF (NSF International)
 - PRCA (Professional Ropes Course Association)
 - RESNET (Residential Energy Services Network, Inc.)
 - SAE (SAE International)
 - TCNA (Tile Council of North America)
 - TIA (Telecommunications Industry Association)
 - UL (Underwriters Laboratories)

To obtain additional information with regard to these standards, including contact information at the ANSI Accredited Standards Developer, please visit ANSI Online at www.ansi.org/asd, select “American National Standards Maintained Under Continuous Maintenance.” Questions? psa@ansi.org.

ANSI-Accredited Standards Developers (ASD) Contacts

The addresses listed in this section are to be used in conjunction with standards listed in PINS, Call for Comment, Call for Members and Final Actions. This section is a list of developers who have submitted standards for this issue of *Standards Action* – it is not intended to be a list of all ANSI-Accredited Standards Developers. Please send all address corrections to the PSA Department at psa@ansi.org.

AAFS

American Academy of Forensic Sciences
410 North 21st Street
Colorado Springs, CO 80904
www.aafs.org

Teresa Ambrosius
tambrosius@aafs.org

AAMI

Association for the Advancement of
Medical Instrumentation
901 N. Glebe Road, Suite 300
Arlington, VA 22203
www.aami.org

Amanda Benedict
abenedict@aami.org

ACI

American Concrete Institute
38800 Country Club Drive
Farmington Hills, MI 48331
www.concrete.org

Shannon Banchemo
shannon.banchemo@concrete.org

ACP

American Clean Power Association
1501 M Street NW, Suite 900
Washington, DC 20005
www.cleanpower.org

Michele Mihelic
standards@cleanpower.org

ADA (Organization)

American Dental Association
211 East Chicago Avenue
Chicago, IL 60611
www.ada.org

Paul Bralower
bralowerp@ada.org

AGMA

American Gear Manufacturers Association
1001 N Fairfax Street, 5th Floor
Alexandria, VA 22314
www.agma.org

Amir Aboutaleb
tech@agma.org

AMCA

Air Movement and Control Association
30 West University Drive
Arlington Heights, IL 60004
www.amca.org

Shruti Kohli-Bhargava
shrutik@amca.org

ANS

American Nuclear Society
555 North Kensington Avenue
La Grange Park, IL 60526
www.ans.org

Kathryn Murdoch
kmurdoch@ans.org

APCO

Association of Public-Safety
Communications Officials-International
351 N. Williamson Boulevard
Daytona Beach, FL 32114
www.apcointl.org

Mindy Adams
apcostandards@apcointl.org

ASABE

American Society of Agricultural and
Biological Engineers
2950 Niles Road
Saint Joseph, MI 49085
<https://www.asabe.org/>

Carla VanGilder
vangilder@asabe.org

ASC X9

Accredited Standards Committee X9,
Incorporated
275 West Street, Suite 107
Annapolis, MD 21401
www.x9.org

Ambria Frazier
Ambria.frazier@x9.org

ASHRAE

American Society of Heating, Refrigerating
and Air-Conditioning Engineers, Inc.
180 Technology Parkway
Peachtree Corners, GA 30092
www.ashrae.org

Carmen King
cking@ashrae.org

Emily Toto
etoto@ashrae.org

Mark Weber
mweber@ashrae.org

ASME

American Society of Mechanical Engineers
Two Park Avenue, 6th Floor
New York, NY 10016
www.asme.org

Maria Acevedo
ansibox@asme.org

ASME

American Society of Mechanical Engineers
Two Park Avenue, M/S 6-2B
New York, NY 10016
www.asme.org

Terrell Henry
ansibox@asme.org

ASTM

ASTM International
100 Barr Harbor Drive
West Conshohocken, PA 19428
www.astm.org

Corice Leonard
accreditation@astm.org

Laura Klineburger
accreditation@astm.org

AWI

Architectural Woodwork Institute
46179 Westlake Drive, Suite 120
Potomac Falls, VA 20165
www.awinet.org

Cheryl Dermyre
cdermyre@awinet.org

ANSI-Accredited Standards Developers Contact Information

AWWA

American Water Works Association
6666 W. Quincy Avenue
Denver, CO 80235
www.awwa.org
Paul Olson
polson@awwa.org

CSA

CSA America Standards Inc.
8501 East Pleasant Valley Road
Cleveland, OH 44131
www.csagroup.org
Debbie Chesnik
ansi.contact@csagroup.org

HL7

Health Level Seven
3300 Washtenaw Avenue, Suite 227
Ann Arbor, MI 48104
www.hl7.org
Karen Van Hentenryck
Karenvan@HL7.org

HPS (ASC N13)

Health Physics Society
1313 Dolley Madison Blvd, Suite 402
McLean, VA 22101
www.hps.org
Amy Wride-Graney
awride-graney@burkinc.com

ICC

International Code Council
4051 Flossmoor Road
Country Club Hills, IL 60478
www.iccsafe.org
Karl Aittaniemi
kaittaniemi@iccsafe.org

NECA

National Electrical Contractors Association
1201 Pennsylvania Avenue, Suite 1200
Washington, DC 20004
www.neca-neis.org
Aga Golriz
Aga.golriz@necanet.org

NEMA (ASC C8)

National Electrical Manufacturers
Association
1300 North 17th Street, Suite 900
Arlington, VA 22209
www.nema.org

Khaled Masri
Khaled.Masri@nema.org

NFPA

National Fire Protection Association
One Batterymarch Park
Quincy, MA 02169
www.nfpa.org

Dawn Michele Bellis
dbellis@nfpa.org

NSF

NSF International
789 N. Dixboro Road
Ann Arbor, MI 48105
www.nsf.org

Allan Rose
arose@nsf.org

Jason Snider
jsnider@nsf.org

Monica Leslie
mleslie@nsf.org

OPEI

Outdoor Power Equipment Institute
1605 King Street, 3rd Floor
Alexandria, VA 22314
www.opei.org

Brandon Martin
bmartin@opei.org

SCTE

Society of Cable Telecommunications
Engineers
140 Philips Rd
Exton, PA 19341
www.scte.org

Kim Cooney
kcooney@scte.org

TAPPI

Technical Association of the Pulp and
Paper Industry
15 Technology Parkway, Suite 115
Peachtree Corners, GA 30092
www.tappi.org

William Millians
standards@tappi.org

TNI

The NELAC Institute
PO Box 2439
Weatherford, TX 76086
www.NELAC-Institute.org

Robert Wyeth
robert.wyeth@nelac-institute.org

UL

Underwriters Laboratories
12 Laboratory Drive
Research Triangle Park, NC 27709
https://ul.org/

Jonette Herman
Jonette.A.Herman@ul.org

Nicolette Weeks
Nicolette.A.Weeks@ul.org

Vickie Hinton
Vickie.T.Hinton@ul.org

UL

Underwriters Laboratories
333 Pflugsten Road
Northbrook, IL 60062
https://ul.org/

Elizabeth Northcott
Elizabeth.Northcott@ul.org

Heather Sakellariou
Heather.Sakellariou@ul.org

UL

Underwriters Laboratories
47173 Benicia Street
Fremont, CA 94538
https://ul.org/

Derrick Martin
Derrick.L.Martin@ul.org

Linda Phinney
Linda.L.Phinney@ul.org

Marcia Kawate
Marcia.M.Kawate@ul.org

VITA

VMEbus International Trade Association
(VITA)
929 W. Portobello Avenue
Mesa, AZ 85210
www.vita.com
Jing Kwok
jing.kwok@vita.com

ISO & IEC Draft International Standards



This section lists proposed standards that the International Organization for Standardization (ISO) and the International Electrotechnical Commission (IEC) are considering for approval. The proposals have received substantial support within the technical committees or subcommittees that developed them and are now being circulated to ISO and IEC members for comment and vote. Standards Action readers interested in reviewing and commenting on these documents should order copies from ANSI.

COMMENTS

Comments regarding ISO documents should be sent to ANSI's ISO Team (isot@ansi.org); comments on ISO documents must be submitted electronically in the approved ISO template and as a Word document as other formats will not be accepted.

Those regarding IEC documents should be sent to Tony Zertuche, General Secretary, USNC/IEC, at ANSI's New York offices (tzertuche@ansi.org). The final date for offering comments is listed after each draft.

ORDERING INSTRUCTIONS

ISO and IEC Drafts can be made available by contacting ANSI's Customer Service department. Please e-mail your request for an ISO or IEC Draft to Customer Service at sales@ansi.org. When making your request, please provide the date of the Standards Action issue in which the draft document you are requesting appears.

ISO Standards

Agricultural food products (TC 34)

ISO/DIS 734, Oilseed meals - Determination of oil content - Extraction method with hexane (or light petroleum) - 4/9/2022, \$46.00

ISO/DIS 12872, Olive oils and olive-pomace oils - Determination of the 2-glycerol monopalmitate content - 4/9/2022, \$62.00

ISO/DIS 22935-1, Milk and milk products - Sensory analysis - Part 1: General guidance for the recruitment, selection, training and monitoring of assessors - 4/15/2022, \$71.00

ISO/DIS 22935-2, Milk and milk products - Sensory analysis - Part 2: Recommended methods for sensory evaluation - 4/15/2022, \$82.00

ISO/DIS 22935-3, Milk and milk products - Sensory analysis - Part 3: Guidance on a method for evaluation of compliance with product specifications for sensory properties by scoring - 4/15/2022, \$46.00

Aircraft and space vehicles (TC 20)

ISO/DIS 24355, General requirements of flight control system for civil small and light multirotor UAS - 4/10/2022, \$46.00

Corrosion of metals and alloys (TC 156)

ISO/DIS 10062, Corrosion tests in artificial atmosphere at very low concentrations of polluting gas(es) - 4/10/2022, \$58.00

Dentistry (TC 106)

ISO/DIS 3630-4, Dentistry - Endodontic instruments - Part 4: Auxiliary instruments - 4/10/2022, \$77.00

Ergonomics (TC 159)

ISO/DIS 25062, Systems and software engineering - Systems and Software Quality Requirements and Evaluation (SQuRE) - Common Industry Format (CIF) for usability: Quantitative usability test report - 4/10/2022, \$82.00

Fluid power systems (TC 131)

ISO/DIS 16030, Pneumatic fluid power - Connections - Ports and stud ends - 11/22/2021, \$67.00

Industrial automation systems and integration (TC 184)

ISO/DIS 8000-51, Data quality - Part 51: Data governance: Exchange of data policy statements - 4/9/2022, \$46.00

ISO/DIS 8000-117, Data quality - Part 117: Application of ISO 8000 -115 to identifiers in distributed ledgers including blockchains - 4/9/2022, \$40.00

Innovation management (TC 279)

ISO/DIS 56007, Innovation management - Tools and methods for idea management - Guidance - 4/15/2022, \$125.00

Materials, equipment and offshore structures for petroleum and natural gas industries (TC 67)

ISO/DIS 16961, Petroleum, petrochemical and natural gas industries - Internal coating and lining of steel storage tanks - 4/8/2022, \$107.00

Metallic and other inorganic coatings (TC 107)

ISO/DIS 6769, Vitreous and porcelain enamels - Determination of surface scratch hardness according to the Mohs scale - 11/21/2021, \$33.00

ISO/DIS 13807, Vitreous and porcelain enamels - Determination of crack formation temperature in the thermal shock testing of enamels for the chemical industry - 11/20/2021, \$46.00

ISO/DIS 28765, Vitreous and porcelain enamels - Design of bolted steel tanks for the storage or treatment of water or municipal or industrial effluents and sludges - 11/21/2021, \$88.00

Natural gas (TC 193)

ISO/DIS 2613-1, Analysis of natural gas - Silicon content of biomethane - Part 1: Determination of total silicon content by AES - 4/15/2022, \$62.00

Non-destructive testing (TC 135)

ISO/DIS 7963, Non-destructive testing - Ultrasonic testing - Specification for calibration block No. 2 - 11/20/2021, \$53.00

Nuclear energy (TC 85)

ISO/DIS 23588, Radiological protection - General requirements for proficiency tests for in vivo radiobioassay - 4/15/2022, \$62.00

Optics and optical instruments (TC 172)

ISO/DIS 12870, Ophthalmic optics - Spectacle frames - Requirements and test methods - 11/25/2021, \$112.00

Paints and varnishes (TC 35)

ISO/DIS 22553-15, Paints and varnishes - Electro-deposition coatings - Part 15: Permeate residues - 4/8/2022, \$40.00

Photography (TC 42)

ISO/DIS 18937-1, Imaging materials - Photographic reflection prints - Methods for measuring indoor light stability - Part 1: General guidance - Part 1: General guidance - 4/14/2022, \$67.00

Road vehicles (TC 22)

ISO/DIS 15830-4, Road vehicles - Design and performance specifications for the WorldSID 50th percentile male side impact dummy - Part 4: Users manual - 4/14/2022, \$134.00

ISO/FDIS 16844-3, Road vehicles - Tachograph systems - Part 3: Motion sensor communication interface - 3/27/2021, \$88.00

ISO/FDIS 16844-6, Road vehicles - Tachograph systems - Part 6: Diagnostic communication interfaces - 3/27/2021, \$62.00

ISO/FDIS 16844-7, Road vehicles - Tachograph systems - Part 7: Parameters - 3/27/2021, \$125.00

ISO/DIS 20730-2, Road vehicles - Vehicle interface for electronic Periodic Technical Inspection (ePTI) - Part 2: Application and communication requirements conformance test plan - 11/22/2021, \$93.00

Rubber and rubber products (TC 45)

ISO/DIS 23794, Rubber, vulcanized or thermoplastic - Abrasion testing - Guidance - 4/14/2022, \$67.00

Safety of machinery (TC 199)

ISO/DIS 14119.2, Safety of machinery - Interlocking devices associated with guards - Principles for design and selection - 3/13/2022, \$165.00

Ships and marine technology (TC 8)

ISO/DIS 4853, Ships and marine technology - A-frame launch and recovery system - 4/15/2022, \$46.00

ISO/DIS 4864, Ships and marine technology - Jacking system appliances on self-elevating unit - General requirements - 4/15/2022, \$40.00

ISO/DIS 23453, Ships and marine technology - Guidelines for the design and manufacture of the hub cap with fins for a fixed-pitch marine propeller - 4/8/2022, \$46.00

ISO/DIS 24569, Ships and marine technology - External firefighting system test method - 4/10/2022, \$46.00

Small craft (TC 188)

ISO 11591:2020/DAMd 1, Small craft - Field of vision from the steering position - Amendment 1: Title missing - 4/11/2022, \$40.00

Textiles (TC 38)

ISO/DIS 18264, Textile slings - Lifting slings for general purpose lifting operations made from fibre ropes - High modulus polyethylene (HMPE) - 11/25/2021, \$98.00

Tractors and machinery for agriculture and forestry (TC 23)

ISO/DIS 3600, Tractors, machinery for agriculture and forestry, powered lawn and garden equipment - Operators manuals - Content and format - 4/10/2022, \$58.00

Valves (TC 153)

ISO/DIS 5115, Industrial valves - Part-turn valve actuation - 4/16/2022, \$88.00

ISO/DIS 5117, Automatic steam traps - Production and performance characteristic tests - 4/10/2022, \$98.00

Water quality (TC 147)

ISO/DIS 23256, Water quality - Detection of selected congeners of polychlorinated dibenzo-p-dioxins and polychlorinated biphenyls - Method using a flow immunosensor technique - 11/20/2021, \$98.00

Water re-use (TC 282)

ISO/DIS 22519, Membrane based generation of WFI - 4/14/2022, \$46.00

Welding and allied processes (TC 44)

ISO/DIS 12153, Welding consumables - Tubular cored electrodes for gas shielded and non-gas shielded metal arc welding of nickel and nickel alloys - Classification - 11/22/2021, \$53.00

ISO/IEC JTC 1, Information Technology

ISO/IEC 23000-19:2020/DAMd 3, Information technology - Multimedia application format (MPEG-A) - Part 19: Common media application format (CMAF) for segmented media - Amendment 3: 8K HEVC, 4K HFR HEVC and Chroma Location for CMAF - 4/8/2022, \$40.00

ISO/IEC DIS 1989, Information technology - Programming languages, their environments and system software interfaces - Programming language COBOL - 11/25/2021, \$323.00

ISO/IEC DIS 23894, Information technology - Artificial intelligence - Risk management - 11/22/2021, \$93.00

- ISO/IEC DIS 5087-1, Information technology - City data model - Part 1: Foundation level concepts - 4/10/2022, \$119.00
- ISO/IEC DIS 15444-8, Information technology - JPEG 2000 image coding system - Part 8: Secure JPEG 2000 - 11/25/2021, \$165.00
- ISO/IEC DIS 18181-3, Information technology - JPEG XL Image Coding System - Part 3: Conformance testing - 11/21/2021, \$46.00
- ISO/IEC DIS 21838-3, Information technology - Top-level ontologies (TLO) - Part 3: Descriptive ontology for linguistic and cognitive engineering (DOLCE) - 11/21/2021, \$53.00
- ISO/IEC DIS 21838-4, Information technology - Top-level ontologies (TLO) - Part 4: TUpper - 11/21/2021, \$71.00
- ISO/IEC DIS 23092-2, Information technology - Genomic information representation - Part 2: Coding of genomic information - 11/22/2021, \$185.00
- ISO/IEC DIS 23465-1, Card and security devices for personal identification - Programming interface for security devices - Part 1: Introduction and architecture description - 4/10/2022, \$82.00
- ISO/IEC DIS 23090-19, Information technology - Coded representation of immersive media - Part 19: Reference Software for V-PCC - 11/25/2021, \$33.00
- ISO/IEC/IEEE FDIS 8802-11, Telecommunications and information exchange between systems - Specific requirements for local and metropolitan area networks - Part 11: Wireless LAN medium access control (MAC) and physical layer (PHY) specifications -, FREE

IEC Standards

- 15/965/CD, IEC 60674-3-7 ED2: Plastic films for electrical purposes - Part 3: Specifications for individual materials - Sheet 7: Fluoroethylene-propylene (FEP) films used for electrical insulation, 04/15/2022
- 20/2011/CDV, IEC 60287-1-1 ED3: Electric cables - Calculation of the current rating - Part 1-1: Current rating equations (100% load factor) and calculation of losses - General, 04/15/2022
- 20/2012/CDV, IEC 60287-1-2 ED2: Electric cables - Calculation of the current rating - Part 1: Current rating equations (100% load factor) and calculations of losses - Section 2: Sheath eddy current loss factors for two circuits in flat formation, 04/15/2022
- 20/2013/CDV, IEC 60287-1-3 ED2: Electric cables - Calculation of the current rating - Part 1-3: Current rating equations (100% load factor) and calculation of losses - Current sharing between parallel single-core cables and calculation of circulating current losses, 04/15/2022
- 20/2017/FDIS, IEC 62067 ED3: Power cables with extruded insulation and their accessories for rated voltages above 150 kV ($U_m = 170$ kV) up to 500 kV ($U_m = 550$ kV) - Test methods and requirements, 03/04/2022

- 44/943/CD, IEC TS 63074 ED1: Safety of machinery - Security aspects related to functional safety of safety-related control systems, 03/18/2022
- 46A/1545/CDV, IEC 61196-1-125 ED1: Coaxial communication cable - Part 1-125: Electrical test methods - Test for equivalent permittivity and equivalent dissipation loss of dielectric, 04/15/2022
- 65E/873/CD, IEC TR 62453-43 ED1: Field Device Tool (FDT) Interface Specification - Part 43: Object model integration profile - CLI and HTML, 04/15/2022
- 65E/874/CD, IEC TR 62453-53-31 ED1: Field Device Tool (FDT) Interface Specification - Part 53-31: Communication implementation for CLI and HTML - IEC 61784 CP 3/1 and CP 3/2, 04/15/2022
- 65E/875/CD, IEC TR 62453-53-90 ED1: Field Device Tool (FDT) Interface Specification - Part 53-90: Communication implementation for CLI and HTML - IEC 61784 CPF 9, 04/15/2022
- 86A/2158/CDV, IEC 60794-1-305 ED1: Optical fibre cables - Part 1 -305: Generic specifications - Basic optical cable test procedures - Cable element test methods - Ribbon tear (separability), Method G5, 04/15/2022
- 86A/2160/CDV, IEC 60794-1-309 ED1: Optical fibre cables - Part 1 -309: Generic specification - Basic optical cable test procedures - Cable element test methods - Bleeding and evaporation of filling or flooding compounds, Method G9, 04/15/2022
- 86B/4561/CDV, IEC 61754-37 ED1: Fibre optic interconnecting devices and passive components - Fibre optic connector interfaces - Part 37: Type MDC connector family, 04/15/2022
- 121/90/NP, PNW 121-90 ED1: Low-voltage switchgear and controlgear - Product data and properties for information exchange - Engineering data - Part 2-2: Switchgear and controlgear assembly objects for building information modelling, 03/18/2022
- 122/129/NP, PNW TS 122-129 ED1: UHV AC Transmission Systems - Security and Stability Requirements for System Planning and Design, 03/18/2022
- Cables, wires, waveguides, r.f. connectors, and accessories for communication and signalling (TC 46)**
- 46A/1546/CDV, IEC 61196-10 ED2: Coaxial communication cables - Part 10: Sectional specification for semi-rigid cables with fluoropolymer dielectric, 04/15/2022
- 46A/1547/CDV, IEC 61196-10-1 ED2: Coaxial communication cables - Part 10-1: Blank detail specification for semi-rigid cables with fluoropolymer dielectric, 04/15/2022
- 46C/1208/CDV, IEC 61156-1 ED4: Multicore and symmetrical pair/quad cables for digital communications - Part 1: Generic specification, 04/15/2022
- 46F/602(F)/FDIS, IEC 63138-3 ED1: Multi-channel radio frequency connectors - Part 3: Sectional specification for MQ5 series circular connectors, 02/04/2022

Capacitors and resistors for electronic equipment (TC 40)

40/2919/CD, IEC 60393-4 ED3: Potentiometers for use in electronic equipment - Part 4: Sectional specification: Single-turn rotary power potentiometers, 04/15/2022

Electric cables (TC 20)

20/2015/CDV, IEC 60287-2-1 ED3: Electric cables - Calculation of the current rating - Part 2-1: Thermal resistance - Calculation of the thermal resistance, 04/15/2022

Electrical Energy Storage (EES) Systems (TC 120)

120/262/DTS, IEC TS 62933-3-3 ED1: Electrical Energy Storage (EES) Systems - Part 3-3: Planning and performance assessment of electrical energy storage systems - Additional requirements for energy intensive and backup power applications, 04/15/2022

120/263/DTS, IEC TS 62933-3-2 ED1: Electrical Energy Storage (EES) Systems - Part 3-2: Planning and performance assessment of electrical energy storage systems - Additional requirements for power intensive and renewable energy sources integration related applications, 04/15/2022

Electrical equipment in medical practice (TC 62)

62A/1472/DTR, IEC TR 60878 ED4: Graphical symbols for electrical equipment in medical practice, 03/18/2022

62C/830/CDV, IEC 61676 ED2: Medical electrical equipment - Dosimetric instruments used for non-invasive measurement of X-ray tube voltage in diagnostic radiology, 04/15/2022

Electroacoustics (TC 29)

29/1109(F)/FDIS, IEC 60645-6 ED2: Electroacoustics - Audiometric equipment - Part 6: Instruments for the measurement of otoacoustic emissions, 02/18/2022

29/1111/FDIS, IEC 60318-8 ED1: Electroacoustics - Simulators of human head and ear - Part 8: Acoustic coupler for high-frequency measurements of hearing aids and earphones coupled to the ear by means of ear inserts, 03/04/2022

Electromagnetic compatibility (TC 77)

77A/1138/CD, IEC TS 61000-3-16 ED1: Electromagnetic compatibility (EMC) - Part 3-16: Limits - Limits for currents produced by the inverter of inverter-type electrical energy-supplying equipment with a reference current less than or equal to 75 A per phase connected to public low-voltage systems, 04/15/2022

Evaluation and Qualification of Electrical Insulating Materials and Systems (TC 112)

112/561/FDIS, IEC 60587 ED4: Electrical insulating materials used under severe ambient conditions - Test methods for evaluating resistance to tracking and erosion, 03/04/2022

Fibre optics (TC 86)

86A/2156/CDV, IEC 60794-1-1 ED5: Optical fibre cables - Part 1-1: Generic specification - General, 04/15/2022

86A/2159/CDV, IEC 60794-2-10 ED3: Optical fibre cables - Part 2-10: Indoor optical fibre cables - Family specification for simplex and duplex cables, 04/15/2022

86A/2166/CDV, IEC 60793-1-1 ED5: Optical fibres - Part 1-1: Measurement methods and test procedures - General and guidance, 04/15/2022

High-voltage testing techniques (TC 42)

42/400/CD, IEC 60270 ED4: High-voltage test techniques - Charge-based measurement of partial discharges, 04/15/2022

42/401/CD, IEC 60060-2 ED4: High-voltage test techniques - Part 2: Measuring systems, 04/15/2022

Lamps and related equipment (TC 34)

34D/1648/CDV, IEC 62722-2-1 ED2: Luminaire performance - Part 2-1: Particular requirements for LED luminaires, 04/15/2022

Magnetic alloys and steels (TC 68)

68/698/CDV, IEC 60404-12 ED2: Magnetic materials - Part 12: Methods of test for the assessment of thermal endurance of surface insulation coatings on electrical steel strip and sheet, 04/15/2022

Magnetic components and ferrite materials (TC 51)

51/1401A/CDV, IEC 63300 ED1: Test methods for electrical and magnetic properties of magnetic powder cores, 04/08/2022

Measuring equipment for electromagnetic quantities (TC 85)

85/821/FDIS, IEC 60477-1 ED1: Laboratory resistors - Part 1: Laboratory DC resistors, 03/04/2022

85/822/FDIS, IEC 60477-2 ED2: Laboratory resistors - Part 2: Laboratory AC resistors, 03/04/2022

Methods for the Assessment of Electric, Magnetic and Electromagnetic Fields Associated with Human Exposure (TC 106)

106/564(F)/FDIS, IEC/IEEE 63195-2 ED1: Assessment of power density of human exposure to radio frequency fields from wireless devices in close proximity to the head and body (Frequency range of 6 GHz to 300 GHz) - Part 2: Computational procedure, 02/11/2022

106/565(F)/FDIS, IEC/IEEE 63195-1 ED1: Assessment of power density of human exposure to radio frequency fields from wireless devices in close proximity to the head and body (Frequency range of 6 GHz to 300 GHz) - Part 1: Measurement procedure, 02/11/2022

Nanotechnology standardization for electrical and electronic products and systems (TC 113)

113/648/CD, IEC TS 62607-6-17: Nanomanufacturing - Key control characteristics - Part 6-17: Graphene-based materials - Order parameter: XRD and TE, 04/15/2022

113/649/CD, IEC TS 62607-6-22: Nanomanufacturing - Key control characteristics - Part 6-22: Graphene-based materials - Ash content: Incineration, 04/15/2022

Nuclear instrumentation (TC 45)

45B/997/CD, IEC 60761-2 ED3: Equipment for continuous monitoring of radioactivity in gaseous effluents - Part 2: Specific requirements for radioactive aerosol monitors including transuranic aerosols, 04/15/2022

Performance of household electrical appliances (TC 59)

59N/14/CD, IEC 63086-1/AMD1 ED1: Amendment 1 - Household and similar electrical air cleaning appliances - Methods for measuring the performance - Part 1: General requirements, 03/18/2022

Power electronics (TC 22)

22E/229/CD, IEC 62909-3 ED1: Bi-directional grid connected power converters - Part 3: EMC requirements and test methods, 04/15/2022

Power transformers (TC 14)

14/1075/CDV, IEC 60076-19 ED1: Power transformers - Part 19: Rules for the determination of uncertainties in the measurement of the losses on power transformers, 04/15/2022

Primary cells and batteries (TC 35)

35/1479/CDV, IEC 62281/AMD2 ED4: Amendment 2 - Safety of primary and secondary lithium cells and batteries during transport, 04/15/2022

35/1481/Q, Revision of IEC 60086-1 Ed 13.0 Primary batteries - Part 1 General and IEC 60086-2 Ed 14.0 Primary batteries - Part 2 Physical and electrical specifications, 03/04/2022

Safety of household and similar electrical appliances (TC 61)

61/6440/CDV, IEC 60335-2-3 ED7: Household and similar electrical appliances - Safety - Part 2-3: Particular requirements for electric irons, 04/15/2022

61/6441/CDV, IEC 60335-2-17 ED4: Household and similar electrical appliances - Safety - Part 2-17: Particular requirements for blankets, pads, clothing and similar flexible heating appliances, 04/15/2022

61/6442/CDV, IEC 60335-2-16 ED6: Household and similar electrical appliances - Safety - Part 2-16: Particular requirements for food waste disposers, 04/15/2022

61/6443/CDV, IEC 60335-2-8 ED7: Household and similar electrical appliances - Safety - Part 2-8: Particular requirements for shavers, hair clippers and similar appliances, 04/15/2022

61/6444/CDV, IEC 60335-2-85 ED3: Household and similar electrical appliances - Safety - Part 2-85: Particular requirements for fabric steamers, 04/15/2022

61/6445/CDV, IEC 60335-2-54 ED5: Household and similar electrical appliances - Safety - Part 2-54: Particular requirements for surface-cleaning appliances for household use employing liquids or steam, 04/15/2022

61/6446/CDV, IEC 60335-2-21 ED7: Household and similar electrical appliances - Safety - Part 2-21: Particular requirements for storage water heaters, 04/15/2022

61/6447/CDV, IEC 60335-2-27 ED7: Household and similar electrical appliances - Safety - Part 2-27: Particular requirements for appliances for skin exposure to optical radiation, 04/15/2022

61/6448/CDV, IEC 60335-2-114 ED2: Household and similar electrical appliances - Safety - Part 2-114: Particular requirements for self-balancing personal transport devices for use with batteries containing alkaline or other non-acid electrolytes, 04/15/2022

Secondary cells and batteries (TC 21)

21A/781/CDV, IEC 63115-1/AMD1 ED1: Amendment 1 - Secondary cells and batteries containing alkaline or other non-acid electrolytes - Sealed nickel-metal hydride cells and batteries for use in industrial applications - Part 1: Performance, 04/15/2022

Solar photovoltaic energy systems (TC 82)

82/1996(F)/FDIS, IEC 61215-1-2/AMD1 ED2: Amendment 1 - Terrestrial photovoltaic (PV) modules - Design qualification and type approval - Part 1-2: Special requirements for testing of thin-film Cadmium Telluride (CdTe) based photovoltaic (PV) modules, 02/25/2022

82/1997(F)/FDIS, IEC 61215-1-3/AMD1 ED2: Amendment 1 - Terrestrial photovoltaic (PV) modules - Design qualification and type approval - Part 1-3: Special requirements for testing of thin-film amorphous silicon based photovoltaic (PV) modules, 02/25/2022

82/1998(F)/FDIS, IEC 61215-1-4/AMD1 ED2: Amendment 1 - Terrestrial photovoltaic (PV) modules - Design qualification and type approval - Part 1-4: Special requirements for testing of thin-film Cu(In,Ga)(S,Se)₂ based photovoltaic (PV) modules, 02/25/2022

82/2005/CD, IEC 62688 ED2: Concentrator photovoltaic (CPV) modules and assemblies - Safety qualification, 03/18/2022

Surface mounting technology (TC 91)

91/1776/DTR, IEC TR 60068-3-12 ED3: Environmental testing - Part 3 -12: Supporting documentation and guidance - Method to evaluate a possible lead-free solder reflow temperature profile, 03/18/2022

Switchgear and controlgear (TC 17)

17C/833/FDIS, IEC 62271-209/AMD1 ED2: Amendment 1 - High-voltage switchgear and controlgear - Part 209: Cable connections for gas-insulated metal-enclosed switchgear for rated voltages above 52 kV - Fluid-filled and extruded insulation cables - Fluid-filled and dry-type cable-terminations, 03/04/2022

Other

SyCSmartEnergy/199A/NP, PNW TS SYCSMARTENERGY-199 ED1:
Reference Guidance for Energy Service Business Using Thermal
Energy Storage Systems, 04/01/2022

JTC1-SC41/262A/NP, PNW JTC1-SC41-262 ED1: Internet of Things
(IoT) - Functional architecture for resource ID interoperability,
04/08/2022



Newly Published ISO & IEC Standards

Listed here are new and revised standards recently approved and promulgated by ISO - the International Organization for Standardization – and IEC – the International Electrotechnical Commission. Most are available at the ANSI Electronic Standards Store (ESS) at www.ansi.org. All paper copies are available from Standards resellers (<http://webstore.ansi.org/faq.aspx#resellers>).

ISO Standards

Anaesthetic and respiratory equipment (TC 121)

[ISO 4135:2022](#), Anaesthetic and respiratory equipment - Vocabulary, \$48.00

Graphical symbols (TC 145)

[ISO 7010:2019/Amd 5:2022](#), Graphical symbols - Safety colours and safety signs - Registered safety signs - Amendment 5, \$20.00

Microbeam analysis (TC 202)

[ISO 23703:2022](#), Microbeam analysis - Guidelines for misorientation analysis to assess mechanical damage of austenitic stainless steel by electron backscatter diffraction (EBSD), \$149.00

Plastics (TC 61)

[ISO 1888:2022](#), Textile glass - Staple fibres or filaments - Determination of average diameter, \$48.00

[ISO 10365:2022](#), Adhesives - Designation of main failure patterns, \$48.00

Plastics pipes, fittings and valves for the transport of fluids (TC 138)

[ISO 11295:2022](#), Plastics piping systems used for the rehabilitation of pipelines - Classification and overview of strategic, tactical and operational activities, \$225.00

Rubber and rubber products (TC 45)

[ISO 21490:2022](#), Rubber and rubber products - Determination of 2-mercaptobenzothiazole content by high performance liquid chromatography (HPLC), \$73.00

Sieves, sieving and other sizing methods (TC 24)

[ISO 15901-2:2022](#), Pore size distribution and porosity of solid materials by mercury porosimetry and gas adsorption - Part 2: Analysis of nanopores by gas adsorption, \$175.00

Steel (TC 17)

[ISO 683-3:2022](#), Heat-treatable steels, alloy steels and free-cutting steels - Part 3: Case-hardening steels, \$200.00

Terminology (principles and coordination) (TC 37)

[ISO 24613-5:2022](#), Language resource management - Lexical markup framework (LMF) - Part 5: Lexical base exchange (LBX) serialization, \$175.00

Tractors and machinery for agriculture and forestry (TC 23)

[ISO 11806-2:2022](#), Agricultural and forestry machinery - Safety requirements and testing for portable, hand-held, powered brush-cutters and grass-trimmers - Part 2: Machines for use with backpack power unit, \$73.00

ISO Technical Specifications

Paper, board and pulps (TC 6)

[ISO/TS 24498:2022](#), Paper, board and pulps - Estimation of uncertainty for test methods by interlaboratory comparisons, \$73.00

ISO/IEC JTC 1, Information Technology

[ISO/IEC/IEEE 14764:2022](#), Software engineering - Software life cycle processes - Maintenance, \$200.00

IEC Standards

Cables, wires, waveguides, r.f. connectors, and accessories for communication and signalling (TC 46)

[IEC 61196-1-100 Ed. 3.0 en:2022](#), Coaxial communication cables - Part 1-100: Electrical test methods - General requirements, \$25.00

[S+ IEC 61196-1-100 Ed. 3.0 en:2022 \(Redline version\)](#), Coaxial communication cables - Part 1-100: Electrical test methods - General requirements, \$33.00

Fibre optics (TC 86)

[IEC 61280-4-5 Ed. 1.0 b Cor.1:2022](#), Corrigendum 1 - Fibre-optic communication subsystem test procedures - Part 4-5: Installed cabling plant - Attenuation measurement of MPO terminated fibre optic cabling plant using test equipment with MPO interfaces, \$0.00

Flat Panel Display Devices (TC 110)

[IEC 62906-5-5 Ed. 1.0 en:2022](#), Laser displays - Part 5-5: Optical measuring methods of raster-scanning retina direct projection laser displays, \$310.00

Industrial electroheating equipment (TC 27)

[IEC 60519-6 Ed. 4.0 b:2022](#), Safety in installations for electroheating and electromagnetic processing - Part 6: Particular requirements for high frequency dielectric and microwave heating and processing equipment, \$392.00

Maritime navigation and radiocommunication equipment and systems (TC 80)

[IEC 63173-1 Ed. 1.0 b:2021](#), Maritime navigation and radiocommunication equipment and systems - Data interfaces - Part 1: S-421 route plan based on S-100, \$443.00

International Organization for Standardization (ISO)

ISO Proposal for a New Field of ISO Technical Activity

National Gas Fuelling Stations

Comment Deadline: February 25, 2022

AFNOR, the ISO member body for France, has submitted to ISO a proposal for a new field of ISO technical activity on Natural Gas Fuelling Stations, with the following scope statement:

Standardization in the field of design, construction and operation of stations for fuelling compressed natural gas (CNG) and liquefied natural gas (LNG) to vehicles. It includes equipment, safety devices and maintenance.

Anyone wishing to review the proposal can request a copy by contacting ANSI's ISO Team (isot@ansi.org), with a submission of comments to Steve Cornish (scornish@ansi.org) by close of business on **Friday, February 25, 2022**.

Meeting Notices (International)

ANSI Accredited U.S TAG to ISO

TC 299, Robotics

Meeting Times February, March & April 2022

Meeting (1) Meeting Format & Location: Remote via GoToMeeting

Meeting Sponsor/Host: A3, the Association for Advancing Automation

Purpose: Prepare for U.S. participation in upcoming meetings and ballots for ISO TC 299 and its Working Groups

Day/Date/Time: Virtual Session: Thursday, February 17, 2022; 2:30 PM – 4:00 PM (Eastern Time) / 11:30 AM – 1:00 PM (PT)

Meeting (2) Meeting Format & Location: Hybrid; In-person in Memphis, TN; Remote via GoToMeeting

Meeting Sponsor/Host: FedEx; The University of Memphis

Purpose: Discuss procedures for the U.S. TAG; Prepare for U.S. participation in upcoming meetings and ballots for ISO TC 299 and its Working Groups

Day/Date/Time: Tuesday, March 8, 2022; 1:00 PM – 5:15 PM (Central Time) / 11:00 AM – 3:15 PM (PT)

Meeting (3) Meeting Format & Location: Remote via GoToMeeting

Meeting Sponsor/Host: A3, the Association for Advancing Automation

Purpose: Prepare for U.S. participation in upcoming meetings and ballots for ISO TC 299 and its Working Groups

Day/Date/Time: Virtual Session: Wednesday, April 20, 2022; 2:30 PM – 4:00 PM (Eastern Time) / 11:30 AM – 1:00 PM (PT)

For More Information: Contact Carole Franklin, cfranklin@automate.org.

Registration of Organization Names in the United States

The Procedures for Registration of Organization Names in the United States of America (document ISSB 989) require that alphanumeric organization names be subject to a 90-day Public Review period prior to registration. For further information, please contact the Registration Coordinator at (212) 642-4975.

When organization names are submitted to ANSI for registration, they will be listed here alphanumerically.

Alphanumeric names appearing for the first time are printed in bold type. Names with confidential contact information, as requested by the organization, list only public review dates.

Public Review

NOTE: Challenged alphanumeric names are underlined. The Procedures for Registration provide for a challenge process, which follows in brief. For complete details, see Section 6.4 of the Procedures.

A challenge is initiated when a letter from an interested entity is received by the Registration Coordinator. The letter shall identify the alphanumeric organization name being challenged and state the rationale supporting the challenge. A challenge fee shall accompany the letter. After receipt of the challenge, the alphanumeric organization name shall be marked as challenged in the Public Review list. The Registration Coordinator shall take no further action to register the challenged name until the challenge is resolved among the disputing parties.

Proposed Foreign Government Regulations

Call for Comment

U.S. manufacturers, exporters, regulatory agencies and standards developing organizations may be interested in proposed foreign technical regulations notified by Member countries of the World Trade Organization (WTO). In accordance with the WTO Agreement on Technical Barriers to Trade (TBT Agreement), Members are required to notify proposed technical regulations that may significantly affect trade to the WTO Secretariat in Geneva, Switzerland. In turn, the Secretariat issues and makes available these notifications. The purpose of the notification requirement is to provide global trading partners with an opportunity to review and comment on the regulations before they become final.

The USA Inquiry Point for the WTO TBT Agreement is located at the National Institute of Standards and Technology (NIST) in the Standards Coordination Office (SCO). The Inquiry Point distributes the notified proposed foreign technical regulations (notifications) and makes the associated full-texts available to U.S. stakeholders via its online service, Notify U.S. Interested U.S. parties can register with Notify U.S. to receive e-mail alerts when notifications are added from countries and industry sectors of interest to them. To register for Notify U.S., please visit: <http://www.nist.gov/notifyus/>.

The USA WTO TBT Inquiry Point is the official channel for distributing U.S. comments to the network of WTO TBT Enquiry Points around the world. U.S. business contacts interested in commenting on the notifications are asked to review the comment guidance available on Notify U.S. at: <https://tsapps.nist.gov/notifyus/data/guidance/guidance.cfm> prior to submitting comments.

For further information about the USA TBT Inquiry Point, please visit: <https://www.nist.gov/standardsgov/what-we-do/trade-regulatory-programs/usa-wto-tbt-inquiry-point> Contact the USA TBT Inquiry Point at (301) 975-2918; F: (301) 926-1559; E: usatbtep@nist.gov or notifyus@nist.gov.

Public Review (January 2022)

Proposed American National Standard AWI 0400 - Factory Finishing

Draft shows changes made in response to Canvass and Public Comments. This draft is recommended for public review by the Architectural Woodwork Institutes Technical Committee.

To submit a comment on this proposed standard, go to <http://gotoawi.com/standards/awi0400.html> to access the Public Comment Form.
(The Public Comment Form is the only venue through which AWI will be accepting public comments.)

The proposed changes to the current standard are indicated by blue text underlined (for additions) and red text strikethrough and underline (for deletions).

Only these changes to the current standard are open for review and comment at this time. Additional material is provided for context only and is not open for comment except as it relates to the proposed changes.

For the full proposed standard go to <http://gotoawi.com/standards/awi0400.html>.

AWI 0400 - Factory Finishing **Draft Standard - Not for Distribution**

2.0 Scope

2.2 Not Included

- e) [Doors included in the scope of ANSI/WDMA I.S 1A \(latest edition\) and/or ANSI/WDMA I.S 6A \(latest edition\).](#)

3.3.2 Performance Characteristics

TR/OP** System Number	FINISHING TECHNOLOGY TYPE AND NUMBER DESIGNATION												
	Leaquer, Nitrocellulose	Leaquer, Post-Catalyzed	Leaquer, Pre-Catalyzed	Latex Acrylic Water Based	Varnish, Conversion	Oil, Synthetic Penetrating	Polyurethans, Catalyzed	Acrylic - Cross Linking, Water Based	Acrylate Epoxy, Polymer of Urethane, Ur Cure	UV Curable, Water Based	Methyl Catalyzed	Polyurethans, Water Based	Polyester, Catalyzed
Vinegar	3	5	4	4	5	3	5	5	5	5	5	4	5
Lemon Juice	3	5	4	4	5	3	5	5	5	5	5	4	5
Orange Juice	3	5	4	4	5	3	5	5	5	5	5	4	5
Ketchup	3	5	4	4	5	2	5	5	5	5	5	4	5
Coffee	3	5	4	4	5	2	5	5	5	5	5	4	5
Olive Oil	2	5	3	3	5	2	5	5	5	5	5	4	5
Boiling Water	3	5	4	4	5	3	5	5	5	5	5	4	5
Cold Water	5	5	5	5	5	3	5	5	5	5	5	4	5
Nail Polish Remover	1	3	2	2	4	1	4	2	5	5	2	3	4
Household Ammonia	3	5	4	4	5	2	5	2	5	5	4	4	5
VM&P Naphtha	3	5	4	4	5	1	5	5	5	5	4	4	5
Isopropyl Alcohol	1	3	2	1	5	2	5	3	5	5	4	4	5
Wine	3	5	4	4	5	2	5	5	5	5	4	5	5
Windex™	3	4	3	3	5	2	5	4	5	4	3	4	5
409 Cleaner™	3	4	3	4	5	1	5	4	5	5	4	4	5
Lycol™	3	5	5	4	5	2	5	3	5	5	4	4	5
33% Sulfuric Acid	3	5	4	3	5	1	5	5	5	5	4	4	5
77% Sulfuric Acid	1	3	2	1	1	1	4	1	4	3	2	3	4
28% Ammonium Hydroxide	1	3	2	1	5	1	5	2	5	5	4	3	5
Gasoline	1	5	2	2	5	1	5	5	5	5	4	4	4
Murphy's Oil Soap™	5	5	5	5	5	2	5	4	5	5	4	5	5
Vodka 100 Proof	3	5	4	4	5	2	5	3	5	5	4	4	5

1% Detergent	3	5	4	4	5	3	5	5	5	5	4	5	5
10% TSP	3	5	4	4	4	1	5	2	5	5	5	5	5
Wear Index	2	3	4	2	5	1	5	4	5	5	4	5	4

* Denotes finishing technologies identified by the Window and Door Manufacturing Association (WDMA) as applicable to doors addressed in ANSI WDMA I.S.1A and I.S.6A standards.

**TR - Transparent, OP - Opaque

[AWI acknowledges the table above as historical data established through industry use of previous AWI standards. Furthermore, it is intentional that the revised reagent list in CR-1 test method varies from the list above in order to collect and establish new data, allowing for emerging technologies.](#)

3.4.2 Passage Doors, [Integrated Door Opening Assemblies](#)

Tracking number 18i21r1
© 2022 NSF International

Revision to NSF/ANSI 18-2020
Issue 21 Revision 1 (January 2022)

Not for publication. This document is part of the NSF International standard development process. This draft text is for circulation for review and/or approval by a NSF Standards Committee and has not been published or otherwise officially adopted. All rights reserved. This document may be reproduced for informational purposes only.

[Note – the recommended changes to the standard which include the current text of the relevant section(s) indicate deletions by use of ~~strikeout~~ and additions by grey highlighting. Rationale statements are in *red italics* and only used to add clarity; these statements will NOT be in the finished publication.]

NSF/ANSI Standard
for Food Equipment –

Manual food and beverage dispensing equipment

.
.
.

Normative Annex 1 (formerly Annex A)

Methods for preparing and analyzing CIP bacteria surrogate

.
.
.

N-1.8 Culture of *E. coli*

.
.
.

N-1.8.2 Challenge culture preparation

- a) 1 mL of the stock culture shall be transferred to a TSA slant prepared in a French bottle with a surface approximately 75 cm² in area. The media shall then be incubated at 36 ± 1 °C (97 ± 1 °F) for 24 h.
- b) Cells shall be washed from agar surface with 5 mL of SBDW. Agar surface shall be scraped with sterile disposable loops.
- c) The density of *E. coli* culture suspension ~~must~~ shall be between 1 and 5 × 10⁶ colony forming units (CFU) per mL.

.
.
.

Normative Annex 2 (formerly Annex B)

Methods for preparing and analyzing bacteria surrogates

.
.
.

N-2.8 Culture of *B. diminuta*

.
.
.

N-2.8.2 Preparation of challenge suspension

- a) 3 d prior to preparing the challenge suspension, a cryogenically frozen *B. diminuta* strain shall be thawed and one TSB tube per strain inoculated with each stock suspension. Challenge suspension shall be incubated at 30 ± 1 °C (86 ± 1 °F) for 24 h.
- b) 48 h before preparing the challenge suspension, an appropriate amount of SLB shall be inoculated with 2 mL of *B. diminuta* seed culture per liter of SLB. Each strain shall be prepared separately and incubated at 30 ± 1 °C (86 ± 1 °F) for 24 h on rotary shaker at 150 rpm.
- c) On the day of preparing challenge suspension, the organism shall be collected by centrifugation at 2,700 *xg* for 10 min and washed in triplicate in phosphate buffered saline before use. TSA plates shall be allowed to warm to room temperature prior to use.
- d) An aliquot of the SLB culture shall be removed aseptically. Its density shall be determined via direct plating, optical density, or epifluorescence microscopy (or equivalent) for each strain. If direct plating is selected, the plating shall occur following the 48-h incubation period for the challenge stock. The plates shall be incubated at 30 °C (86 °F) for 48 h and read promptly to determine density. The challenge stock shall be held at 4 °C (39 °F) while the plates for density determination are being incubated. The challenge ~~must~~ shall be used within 48 h from initial harvest. Dispersion and morphological characteristics of the challenge culture suspension shall be microscopically examined using Brightfield microscopy and differential staining (i.e., gram stain). 95% of the organisms shall be confirmed to possess the size dimensions of 0.3 µm in width and 0.8 µm in length. A calibrated ocular micrometer shall be used for the size measurements. Bacteria present in the challenge suspension shall also be confirmed to be singlet in arrangement and dispersed in a homogeneous manner.
- e) Based on the determined density of the SLB culture, a suspension shall be prepared containing at least 1×10^6 CFU/mL (not to exceed 5×10^6 CFU/mL). It shall be prepared by combining the three strains in a 1:1:1 ratio to provide a cocktail challenge suspension.
- f) A 10-mL aliquot from the cocktail challenge suspension shall be removed and set aside for density verification. Density verification shall be conducted according to *Standard Methods for the Examination of Water and Wastewater*^{Error! Bookmark not defined.}. Alternate equivalent enumeration methodologies may be utilized if they have been validated according to the guidelines specified by AOAC (Association of Analytical Chemists). The document from Feldstine et al. (Journal of AOAC International vol. 85, No. 5, 2002) entitled "AOAC International Methods Committee Guidelines for Validation of Qualitative and Quantitative Food Microbiological Official Methods of Analysis" details statistical evaluation for determining method validation and equivalency. This article can be found at <members.aoc.org/AOAC_Docs/StandardsDevelopment/AOAC_Validation_Guidelines_for_Food_Microbiology-Prepub_version.pdf.
- g) 24 to 48 h after incubation, colonies on all of the density determination plates shall be counted. The mean microorganisms/mL shall be calculated for plates with 20 to 200 colonies. This is to verify that challenge organism was present in the challenge test water at the optimum concentration before being added to test apparatus.

N-2.9 Culture of *L. innocua***N-2.9.2 Challenge culture preparation**

- a) 1 mL of each stock culture shall be transferred to individual TSA slants prepared in a French bottle with a surface approximately 75 cm² in area. The media shall then be incubated at 35 ± 1 °C (95 ± 1 °F) for 24 h.

Tracking number 18i21r1
© 2022 NSF International

Revision to NSF/ANSI 18-2020
Issue 21 Revision 1 (January 2022)

- b) Cells shall be washed from agar surface with 5 mL of SBDW. Agar surface shall be scraped with sterile disposable loops.
- c) An aliquot of the TSB culture shall be removed aseptically. Its density shall be determined via direct plating, optical density, epifluorescence microscopy (or equivalent method) for each strain. If direct plating is selected, the plating shall occur following the 24-h incubation period for the challenge stock. The plates shall be incubated at 35 °C (95 °F) for 24 h and read promptly to determine density. The challenge stock shall be held at 4 °C (39 °F) while the plates for density determination are being incubated. The challenge ~~must~~ shall be used within 48 h from initial harvest. Based on the density obtained, the volume to be inoculated and the target challenge concentration, an appropriate inoculum shall be prepared in a 1:1:1 ratio.

Rationale: Revised phrase from “must” per ANSI requirements for normative standard language.

Not for publication. This document is part of the NSF International standard development process. This draft text is for circulation for review and/or approval by a NSF Standards Committee and has not been published or otherwise officially adopted. All rights reserved. This document may be reproduced for informational purposes only.

[Note – the recommended changes to the standard which include the current text of the relevant section(s) indicate deletions by use of ~~strikeout~~ and additions by **grey highlighting**. Rationale Statements are in *red italics* and only used to add clarity; these statements will NOT be in the finished publication.]

NSF/ANSI International Standard for Biosafety Cabinetry —

Biosafety Cabinetry: Design, Construction, Performance, and Field Certification

-
-
-

3 Definitions

-

3.8.2.1 Class II Type A1 cabinets (formerly designated Type A): Cabinets that:

- maintain minimum average inflow velocity of 75 ft/min (0.38 m/s) through the work access opening;
- have HEPA/ULPA filtered downflow air that is a portion of the mixed downflow and inflow air from a common plenum (i.e., a plenum from which a portion of the air is exhausted from the cabinet and the remainder supplied to the total work area);
- may exhaust HEPA/ULPA filtered air back into the laboratory or to the environment through an external exhaust system connected to the cabinet with a canopy connection; ~~and~~
- have all biologically contaminated ducts and plenums under negative pressure or surrounded by negative pressure ducts and plenums; ~~and~~
- type A1 BSCs are not designed for work with volatile chemicals and are not suitable to be used for handling these chemicals.

~~If using chemicals with toxic vapors, the unit shall be connected to an external exhaust system. Type A1 cabinets may be used for work with volatile chemicals if deemed appropriate by a chemical risk assessment (refer to Section I-1.3.1.3).~~

~~NOTE — Type A1 BSCs manufactured prior to 2010 are not suitable for work with volatile chemicals due to the contaminated positive pressured plenums that are not surrounded by negative pressure plenums.~~

Not for publication. This document is part of the NSF International standard development process. This draft text is for circulation for review and/or approval by a NSF Standards Committee and has not been published or otherwise officially adopted. All rights reserved. This document may be reproduced for informational purposes only.

Informative Annex 1

(formerly Annex E)

Biosafety cabinet selection, installation, use, lifespan, and decommissioning

The information contained in this Annex is not part of this American National Standard (ANS) and has not been processed in accordance with ANSI's requirements for an ANS. Therefore, this Annex may contain material that has not been subjected to public review or a consensus process. In addition, it does not contain requirements necessary for conformance to this Standard.

•

I-1.3 BSC Class and Type selection

•

I-1.3.1.3 Question three: What types and quantities of chemical vapors will be generated in the BSC?

As important as the preceding question, the user must also foresee the types and quantities of chemical vapors that will be generated in the cabinet. Because chemical vapors can freely pass through HEPA/ULPA filters, both Class I and Class II BSCs must be exhausted out of the laboratory when used with these types of chemicals. For the Class II BSCs, Types B1 and B2 must be direct connected to an external exhaust system in order to operate properly; Types A1, A2, and C1 can be converted to operate in either a canopy ducted or recirculating mode, depending on the users' requirements. The airflow patterns of Types A1, A2, B1, B2 and C1 BSCs are shown in Figures 35, 37, 38 and 40, respectively.

•

I-1.11 Definitions

•

I-1.11.8.2.1 Class II Type A1 cabinets (formerly designated Type A): Cabinets that:

- maintain minimum average inflow velocity of 75 ft/min (0.38 m/s) through the work access opening;
- have HEPA/ULPA filtered downflow air that is a portion of the mixed downflow and inflow air from a common plenum (i.e., a plenum from which a portion of the air is exhausted from the cabinet and the remainder supplied to the total work area);
- may exhaust HEPA/ULPA filtered air back into the laboratory or to the environment through an external exhaust system connected to the cabinet with a canopy connection; and

Tracking #49i161r1
© 2022 NSF International

Revision to NSF/ANSI 49 – 2020
Issue 161, Revision 1 (January 2022)

Not for publication. This document is part of the NSF International standard development process. This draft text is for circulation for review and/or approval by a NSF Standards Committee and has not been published or otherwise officially adopted. All rights reserved. This document may be reproduced for informational purposes only.

— have all biologically contaminated ducts and plenums under negative pressure or surrounded by negative pressure ducts and plenums.

— type A1 BSCs are not designed for work with volatile chemicals and are not suitable to be used for handling these chemicals.

~~If using chemicals with toxic vapors, the unit shall be connected to an external exhaust system. Type A1 cabinets may be used for work with volatile chemicals if deemed appropriate by a chemical risk assessment (refer to Section I-1.3.1.3).~~

~~NOTE—Type A1 BSCs manufactured prior to 2010 are not suitable for work with volatile chemicals due to the contaminated positive pressured plenums that are not surrounded by negative pressure plenums.~~

***Rationale:** during a recent balloted issue, the non-germane topic of the NOTE in section 3.8.2.1 was brought to light. As this language is somewhat dated and the knowledge around the use of various volatile chemicals has evolved, a new issue paper was submitted for the JC to consider. After detailed discussion, the Task Group decided this revised language surrounding the use of A1 BSCs and volatile chemicals was a valuable approach for users to understand the potential limitations of using this type of BSC with volatile chemicals.*

Not for publication. This document is part of the NSF International standard development process. This draft text is for circulation for review and/or approval by an NSF Standards Committee and has not been published or otherwise officially adopted. All rights reserved. This document may be reproduced for informational purposes only.

[Note – the recommended changes to the standard which include the current text of the relevant section(s) indicate deletions by use of ~~strikeout~~ and additions by **gray highlighting**. Rationale statements are in *italics* and only used to add clarity; these statements will NOT be in the finished publication.]

NSF/ANSI/CAN Standard for Drinking Water Additives

Drinking water system components - Lead content

.
.
.

7 Analytical procedures for determining percent lead content of materials

7.1 Lead content screening

Screening may be used to check the lead content in the following cases, but not limited to:

- screening of components where no lead is expected (e.g., certain plastics, elastomers, coatings);
- screening of components where lead is expected for comparison to material specification information; and
- initial screening of components to identify and prioritize items for further testing.

XRF (X-ray fluorescence), OES (optical emission spectroscopy) arc / spark, SEM (scanning electron microscopy) / EDS (energy dispersive spectrometer) are acceptable methods for screening components, provided the instrument is calibrated to standard reference materials. Other applicable screening methods may be employed, provided that adequate performance can be demonstrated. The following should be taken into consideration with a screening method:

- surfaces scanned should be clean, dry, and free of coating. Even slight overspray of coatings can significantly reduce lead content readings;
- part finishes that remove surface lead, such as acid washes, will affect surface lead content readings and may affect the value of the screening analysis;
- part size, shape, and condition of the surface can impact reading. Area analyzed should be no smaller than the instrument observation window. Shapes, such as curved surfaces, should be minimized; and
- lower lead content parts may require longer read times and **may require** the average of several measurements (three or more) with different orientation to produce accurate results.

When considering the points above the screening method may not be suitable for determining lead content, in which case the lead content shall be determined in accordance with Section 7.2

Tracking number 372i6r1
© 2022 NSF International

Revision to NSF/ANSI/CAN 372-2020
Issue 6 Revision 1 (January 2022)

7.2 Lead content analysis of materials

- .
- .
- .

Rationale: Added clarification on the requirements of lower lead content parts.

BSR/UL 60079-47, Explosive Atmospheres – Part 47: Equipment Protection by 2-Wire Intrinsically Safe Ethernet Concept (2-WISE)

1. This proposal provides revisions to the proposal document dated September 24, 2021 per responses to comments received.

PROPOSAL

6 Schedule drawings and instructions for 2-WISE devices

6DV DR Modification of Clause 6 to replace with the following:

These requirements supplement and modify the schedule drawings and instructions requirements of ~~IEC 60079-0~~ UL 60079-0, and ~~IEC 60079-11~~ UL 60079-11 and UL 60079-25 as applicable.

The schedule drawings shall confirm that each 2-WISE device is suitable for use in a 2-WISE system in accordance with this technical specification.

The intrinsic safety parameters need not be included in the certificate or in the instructions for the 2-WISE ports.

Instructions shall contain information indicating that a marked "2-WISE communication only port" shall not be connected to a "2-WISE power source port".

Instructions shall provide the necessary information to produce the descriptive system document.

7.1 General

7.1DV DR Modification of Clause 7.1 to replace with the following:

These requirements supplement and modify the marking requirements of ~~IEC 60079-0~~ UL 60079-0, and ~~IEC 60079-11~~ UL 60079-11 and UL 60079-25 as applicable.

Each 2-WISE device shall be marked "2-WISE".

The type of each port shall be clearly marked, as:

"2-WISE power source"

"2-WISE power load"

"2-WISE auxiliary device"

"2-WISE communication only"

2-WISE ports need not be marked with the intrinsic safety parameters U_i , I_i , C_i , L_i , P_i , U_0 , I_0 , C_0 , L_0 or P_0 .

SPECIAL NOTE FROM THE PROJECT MANAGER: The following editorial revisions to cross-references are not National Differences but the result of systematic formatting errors.

4.1 General

2-WISE devices shall conform to the relevant requirements of IEC 60079-11, except as modified by this document. 2-WISE devices shall be suitable for use in a 2-WISE system in accordance with this document.

Each port shall conform to the requirements of ~~Error! Reference source not found~~ 4.2, θ 4.3 or θ 4.4.

If a termination network is present inside a 2-WISE power source port, power load port or communication only port, which is additional to the specified maximum output values allowed for 2-WISE, presenting a capacitance at the port connection facilities, the effective value of the capacitance shall not exceed 2,2 μ F when the capacitance is protected by a series resistor of minimum value 90 Ω . Other equivalent combinations of capacitance and resistance may also be selected according to the permitted reduction of effective capacitance when protected by a series resistance requirements of IEC 60079-11.

NOTE The dielectric strength requirements for the insulation between the terminals of 2-WISE ports and the frame of the 2-WISE device or parts which are earthed are identical to those required in IEC 60079-11 between an intrinsically safe circuit and the frame of the electrical equipment or parts which are earthed.

4.5 Simple apparatus

The internal inductance L_i and internal capacitance C_i of each simple apparatus connected to a 2-WISE system shall be less than 1 μ H and 1 nF respectively.

With the exception of the marking requirements found in Clause θ 7, simple apparatus shall comply with all relevant requirements of this document and of IEC 60079-11.

5.1 General

A typical 2-WISE system comprises two 2-WISE ports connected to the opposite ends of a cable, with a maximum of two 2-WISE devices with 2-WISE auxiliary device ports in between.

There are two different types of 2-WISE systems:

- the communication only system; and
- the powered system.

The common function is communication. The powered system provides additional supply power in the following manner:

- the power source port supplies DC power to the system, and the power load port consumes DC power from the system. Auxiliary device ports may also consume DC power from the system.
- in an communication only system no DC power is provided to the system via the 2-WISE connection and in this case 2-WISE devices are always separately powered. A communication only port shall not be connected to a power source port.

Simple apparatus according to θ 4.5 may be added to a 2-WISE system without modifying the safety assessment of the system.

The total inductance and capacitance of all simple apparatus connected to a 2-WISE system shall not exceed 10 μH and 5 nF respectively.

NOTE 1 2-WISE connection facilities or electromechanical switches are considered as simple apparatus according to θ 4.5 but do not contribute to the total inductance and capacitance.

NOTE 2 For functional reasons, the cable (stubs) for connecting 2-WISE devices with auxiliary device ports in parallel to the 2-WISE system, will be less than 1 m, and are not considered to be part of the total cable length of the 2-WISE system.

5.4 Communication only 2-WISE systems

A communication only 2-WISE system shall be considered intrinsically safe if two 2-WISE communication only ports and up to two 2-WISE auxiliary device ports are connected with a cable of maximum length 1 000 m, according to θ 5.2 and as shown in Figure 1.

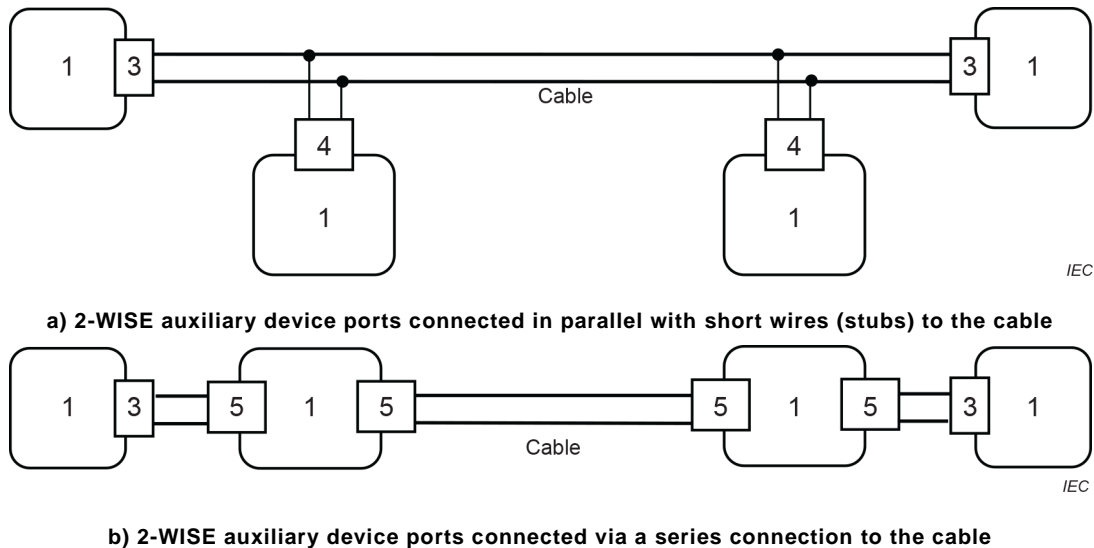

Key

- 1 2-WISE device
- 3 2-WISE communication only port
- 4 2-WISE auxiliary device port
- 5 2-WISE auxiliary device port that is physically split in two termination facilities but electrically connected through and therefore counted as one 2-WISE auxiliary device port per 2-WISE device

Figure 1 – Communication only 2-WISE system

5.5 Descriptive system document

Each interconnection of 2-WISE ports in a 2-WISE system shall be allocated a Level of Protection (for example "ia", "ib" or "ic") determined by the 2-WISE port with the lowest Level of Protection and be allocated an equipment group (for example I, IIA, IIB, IIC, IIIA, IIIB or IIIC) determined by the 2-WISE port with the least onerous equipment group. This shall be documented in the descriptive system document.

The descriptive system document shall contain the confirmation that the permitted maximum ambient temperature of each 2-WISE device is suitable for the intended use.

The temperature class of each 2-WISE device shall be determined and recorded in the descriptive system document, if applicable.

The descriptive system document shall include the parameters of the cable (see θ 5.2) to be connected to a 2-WISE port.

NOTE IEC 60079-25 provides an example of a descriptive system document.

BSR/UL 674, Standard for Electric Motors and Generators for Use in Hazardous (Classified) Locations

1. Revisions for the use of electronic medium for required documentation.

PROPOSAL

51A.2.4 Where some or all of the required instructional material is provided by electronic media, the required instructional material shall be available in printed format upon request of the user.

NOTE 1 Where required instructional material, especially drawings, is provided in an electronic documentation format, consideration should be given by the manufacturer to its viewability and print capability by the user.

NOTE 2 ~~While electronic media are permitted for required instructions as part of national and international standards supported by the NEC, CE Code and IEC Ex System, however~~ other constraints may apply in certain market places (e.g. the European Commission's Standing Committee for the ATEX Directive has taken the view that at least the safety related parts of the instructions in respect of ATEX should be supplied in paper form).

2. Revisions to include +60°C and -60°C explosion testing with test factors using precompression explosion testing equipment.

PROPOSAL

36.3A.1.2 All test sample joints shall be based upon the manufacturers maximum specified gap, and tested with the minimum specified joint length. Specially prepared test samples having modified joint lengths, gaps and engagements shall be employed. For Groups ~~A, B, or A and B~~, test factors per ~~21.23 and 21.26~~ [36.3.2, 36.3.3 or 36.3.4, as applicable](#), shall be introduced into the test pressure or test gap in addition to the test factors above.

Table 36.3A.1G
Test factors to increase pressure or joint test gap

Temperature up to °C	Groups A & B 27.5% H ₂ 7.5% C ₂ H ₂	Group C 37% H ₂	Group D 55% H ₂	Minimum Number of Tests ¹
60*	1.00	1.00	1.00	5
70	1.11	1.04	1.05	5
80	1.13	1.05	1.06	5
90	1.15	1.06	1.07	5
100	1.16	1.06	1.08	5
110	1.18	1.07	1.09	5
120	1.20	1.08	1.10	5
130	1.22	1.09	1.11	5

Temperature up to °C	Groups A & B 27.5% H ₂ 7.5% C ₂ H ₂	Group C 37% H ₂	Group D 55% H ₂	Minimum Number of Tests ¹
¹ The tests are carried out five times with each test mixture. For equipment intended for Group B, only the test with the hydrogen-air mixtures is required. * 65°C in Canada				

37.3A.2 The test shall be made once except for ~~Group A or~~ Group B, in which case the test shall be made three times with each gas mixture as follows:

- Group D: 4.6 ± 0.3 % propane
- Group C: 8 ± 0.5 % ethylene
- Group B: 31 ± 1 % hydrogen
- ~~- Group A: 14 ± 1 % acetylene~~

3. Revisions to remove errors and omissions.

PROPOSAL

1.1 This standard applies to electric motors and generators or submersible and nonsubmersible sewage pumps and systems suitable for use in Class I, Division 1, Groups B, C and D, and Class II, Division 1, Groups E, F and G, hazardous (classified) locations as defined by the *Canadian Electrical Code*, C22.1 Part I ([CE Code](#)), the *National Electrical Code*, ANSI/NFPA 70 (NEC), and *NOM-001-SEDE*.

Note: In the US, the application "hazardous locations" is referred to as "hazardous (classified) locations".

BSR/UL 1004-10, Standard for Pool Pump Motors

Proposal Topic: Addition of glossary term for “Factory Default Setting”

2.7A FACTORY DEFAULT SETTING – Upon application of power at initial installation, the program that the unit will run without outside interference or change by the user.

BSR/UL 1678, Standard for Household, Commercial, and Institutional-Use Carts, Stands and Entertainment Centers for Use with Audio and/or Video Equipment

1. Proposed Revisions To Paragraph 11.1.1 To Specify That Flammability Ratings For Polymeric Parts Are Required Only When The Parts Are Used For Support Or Enclosure Of Live Parts

PROPOSAL

2.10A LIVE PART - Any part where current is flowing.

11.1.1 Polymeric or similar material used in the construction of a cart, stand, or entertainment center that is used as ~~a support or enclosure~~ an enclosure or support for live parts shall have a minimum flammability classification of HB. The flammability classification is to be determined by tests specified in the Standard for Tests for Flammability of Plastic Materials for Parts in Devices and Appliances, UL 94. A material classified using 1/8-inch (3.2-mm) thick bar specimens is able to be employed in thicknesses less than 1/8 inch in the cart, stand or entertainment center.

UL COPYRIGHTED MATERIAL

NOT AUTHORIZED FOR FURTHER REPRODUCTION OR DISTRIBUTION WITHOUT PERMISSION FROM UL INC.

Standard: UL 4600**Standard Title:** Standard for Safety for Evaluation of Autonomous Products**Date of Proposal:** January 28, 2022**Comments Due:** February 28, 2022

SUMMARY OF TOPICS

The following is being recirculated for your review:

1. Revise Requirements regarding Safety Case (Section 5)

3. Revise Requirements in Assessment, Section 3

Need access to the full standard or a standard this proposal references? [Click here](#) to learn more about accessing UL and ULC Standards. STP and TC Members can find the latest copy of the standard under their My STPs or My Committees tab in CSDS.

For your convenience in review, proposed additions to the previously proposed requirements dated 2021-10-29 are shown underlined and proposed deletions are shown ~~lined-out~~.

1. Revise Requirements regarding Safety Case (Section 5)

RATIONALE

Responses to comments have been posted within the UL 4600 Proposal Review Work Area dated 2021-10-29.

PROPOSAL

5.3.2.1 MANDATORY:

a)Support safety case claims by acceptable argument

1)Argument explaining why readers should conclude that the ~~kinds~~ of evidence cited ~~are~~ is a sufficient basis for believing that the safety requirements are satisfied

NOTE: Where satisfaction of each of a set of similar requirements is shown by the same kinds of evidence, this argument need not be repeated for each individual requirement so long as it is clear which collective argument applies to each requirement.

NOTE: Kinds of evidence are discussed in 5.4.1.

2) Traceability from safety requirements to the artifacts used as evidence of their satisfaction

b) Identify criteria used to determine sufficiency of arguments

5.3.2.2 REQUIRED:

a) Identify strategy for addressing epistemic defeaters in arguments

NOTE: Many of the prompt elements in other clauses are epistemic defeaters.

Additionally, reviews of the safety argument can include consideration as to whether any additional epistemic defeaters are applicable.

b) **Pitfall:** Taking credit for conformance to a safety standard without specifically describing the limitations of the conformance assessment is prone to over-crediting safety attributes. (*) See 5.3.2.6.1.

NOTE: This is in effect an argument gap that does not support the identified claim(s). See also Section 5.7.

c) **Pitfall:** Taking credit for conformance to a safety standard designed for human operated equipment is prone to missing fault management control obligations implicitly placed upon autonomy. (*) See 5.3.2.6.1.

NOTE: This is a special, but important, case of the preceding Pitfall regarding limitations of conformance assessment to a safety standard.

EXAMPLE: Credit taken for ego vehicle controllability in assessing ISO 26262 conformance places a corresponding controllability obligation upon autonomy functions to exercise that same level of control. The need to argue a replacement for the human to provide the controllability assumed as part of ISO 26262 ASIL assignment might be missed if this Pitfall is not addressed.

5.3.2.6.1 **REFERENCE:** (*) For discussion of the Pitfalls named in 5.3.2.2.b and 5.3.2.2.c, and Pitfalls generally, see generally: Koopman, P., Kane, A. & Black, J., "Credible Autonomy Safety Arguments," Safety-Critical Systems Symposium, Bristol UK, Feb. 2019.

5.3.3.2 REQUIRED:

- a) Avoid identified logical fallacies
- b) Avoid identified rhetorical devices
- c) **Pitfall:** Taking credit for proven in use technology that is used in a different operational environment or for a different purpose is prone to over-crediting safety attributes. (*) See 5.3.3.6.1.
 - 1) This Pitfall specifically includes COTS, legacy, and EooC components, including hardware and/or software

(NOTE: See Section 13.4)
 - 2) This Pitfall specifically includes changes in item operational parameters that might be relevant to the component

EXAMPLE: For an example of an accident where a change in the operational parameters for a flight guidance component led to the loss of a spacecraft, see Lions, J.L., Ariane 5 Flight 501 Failure, Report by the Inquiry Board, 1996
- d) **Pitfall:** Discounting failures in field engineering feedback because the failure cannot be reproduced, has not recurred, or has not led to an accident or other adverse outcome is prone to inductively discounting multiple failures that, if taken as a set, substantively demonstrate invalidity of a safety case. (*) See 5.3.3.6.1.
- e) **Pitfall:** Arguing coverage of autonomous failure analysis based on data from human-operated item is prone to missing some types of failures, including: (*) See 5.3.3.6.1.
 - 1) Failures that are triggered by operational situations an autonomous item might enter that human operators typically avoid
 - 2) Failures atypical of human mistakes that an autonomous item fault could trigger
- f) **Pitfall:** Arguing risk mitigation via analysis of operational data and/or test data based on arrival rate of incidents (“surprises” or other potential failures) is prone to: (*) See 5.3.3.6.1.
 - 1) Overlooking the additional compounding factor of the distribution of the

means of different types of root causes

EXAMPLE: A heavy tail distribution of mean arrival rates of different types of triggering events for item failures

2) Overlooking the potential effects of infrequent but inevitable common cause events

EXAMPLES: Leap seconds, GPS date rollover, daylight savings time changes, or other time keeping anomalies

g) **Pitfall:** Arguing test coverage based upon human-designed test planning is prone to overlooking edge cases that apply to autonomous functions but would not generally be considered edge cases by a human operator. (*) See 5.3.3.6.1.

h) **Pitfall:** Arguing item correctness based upon use of formal methods is prone to overlooking any invalidities in underlying assumptions made by the proofs. (*) See 5.3.3.6.1.

i) **Pitfall:** Arguing that risk is low for a known hazard or variance from expected behavior based upon operational experience alone is prone to underestimating the possibility of catastrophic outcomes.

EXAMPLE: For an example of an accident preceded by deviations from expected behavior, see Rogers Commission Report; Report of Columbia Accident Investigation Board, 1986

j) **Pitfall:** Arguing low risk based upon unvalidated simulation results alone is prone to missing risks due to simulation defects, modeling faults, and simplifications made in the abstraction process to create the simulation.

5.3.3.6.1 REFERENCE: (*) For discussion of the Pitfalls named in 5.3.3.2.c, 5.3.3.2.d, 5.3.3.2.e, 5.3.3.2.f, 5.3.3.2.g, and 5.3.3.2.h, and Pitfalls generally, see generally: Koopman, P., Kane, A. & Black, J., "Credible Autonomy Safety Arguments," Safety-Critical Systems Symposium, Bristol UK, Feb. 2019.

5.7.1.6.1 NOTE: A primary goal of this clause is to ensure that aspects of the item that can contribute to or mitigate risk are identified to ensure inclusion in the safety case. While the safety argument covers these matters, it might do so by reference to documentation such as specification and design documents. For example, argument explaining why readers should believe hazards are addressed or requirements are satisfied (see Sections 5.3.1 and 5.3.2) will mention interfaces and refer readers to

primary documentation of those interfaces. Argument showing readers why fault model coverage is acceptable refers to clear documentation of the fault models used.

3. Revise Requirements in Assessment, Section 3

RATIONALE

Responses to comments have been posted within the UL 4600 Proposal Review Work Area dated 2021-10-29.

PROPOSAL

4.1.1 Commonly used constructions of this standard affect the safety case as follows. All elements are normative except “EXAMPLE,” and “REFERENCE” statements as well as any other content that is explicitly stated to be informative. (See Table 4.1 below for a summary of key safety case deviation explanations.)

(NOTE – Paragraph 4.1.1 not shown in its entirety)

g) **CONFORMANCE statements.** Conformance with each clause is evaluated via both self-assessment and independent assessment according to Section 17. Each clause has a conformance statement that provides guidance identifying portions of the safety case and other information sources that are especially relevant to assessing conformance to that clause. Assessors are permitted to consider objective evidence beyond the conformance statement when the assessor determines that the situation warrants, but are limited in conformance determination by the written scope of the clause. (~~Self-auditors~~ Both self-assessors and independent assessors can and should consider whether prompt elements beyond those included in this standard need to be added for a particular item’s safety case.) Conformance checks are performed by someone other than the developer of the item being checked for conformance (See Section 17). (There are limited exceptions for safety case artifacts being ~~self-audited~~ self-assessed; see Section 17.2.2.)

Copyright © 2022 Underwriters Laboratories Inc.

ASSE Series 6000

Professional Qualifications Standard for

Medical Gas Systems Personnel

35-2.3 Product Installation Knowledge

35-2.3.1 The Bulk Medical Gas/Cryogenic Fluid Central Supply Systems Verifier shall be able to identify and describe the proper installation requirements for bulk medical gas/cryogenic fluid central supply system pertaining to:

- ~~a) The firm's standing operating procedures (SOPs)~~
- b) Manufacturer recommendations
- c) The first filling of a cryogenic vessel
 - 1) Vessel purging
 - 2) Vessel cool down
- d) System purging
- e) Physical location
 - 1) Ventilation
 - 2) Accessibility
- f) Local jurisdiction requirements

35-2.3.2 The Bulk Medical Gas/Cryogenic Fluid Central Supply Systems Verifier shall be able to identify and describe the problems resulting from the improper installation of bulk medical gas/cryogenic fluid central supply systems.